

Air Cooling Energy Storage System

TRENE-P100B215

User Manual

Version 3.0

www.solaxpower.com



eManual in the QR code or
at www.solaxpower.com

STATEMENT

Copyright

Copyright © SolaX Power Network Technology (Zhejiang) Co., Ltd. All rights reserved.

No part of this manual may be reproduced, transmitted, transcribed, stored in a retrieval system, or translated into any language or computer language, in any form or by any means without the prior written permission of SolaX Power Network Technology (Zhejiang) Co., Ltd.

Trademarks



SOLA^X and other symbol or design (brand name, logo) that distinguishes the products or services offered by SolaX has been trademark protected. Any unauthorized use of the above stated trademark may infringe the trademark right.

Notice

Please note that certain products, features, and services mentioned in this document may not be within the scope of your purchase or usage. Unless otherwise specified in the contract, the contents, information, and recommendations presented in this document are provided "as is" by SolaX. We do not provide any warranties, guarantees, or representations, whether express or implied.

The content of the documents is reviewed and updated as needed. However, occasional discrepancies may occur. SolaX retains the right to make improvements or changes in the product(s) and the program(s) described in this manual at any time without prior notice.

The images included in this document are solely for illustrative purposes and may differ based on the specific product models.

For more detailed information, kindly visit the website of SolaX Power Network Technology (Zhejiang) Co., Ltd. at www.solaxpower.com.

SolaX retains all rights for the final explanation.

About This Manual

Scope of Validity

This manual is an integral part of TRENE-P100B215 intelligent all-in-one energy storage system. It describes the transportation, storage, installation, electrical connection, commissioning, maintenance and troubleshooting of the product. Please read it carefully before operating.

Model description

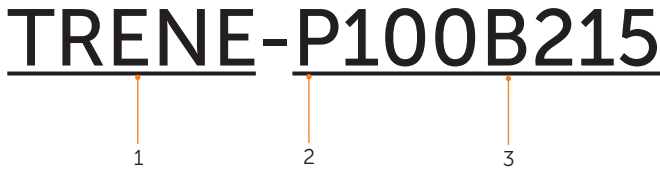

No.	Definition	Description
1	Product name	TRENE: Refer to the name of AC couple series project.
2	Power	P100: Indicate that the rate power of the PCS is 100 kW.
3	Battery capacity	B215: Indicate that the battery capacity is 215 kWh.



Target Group

The installation, maintenance and grid-related setting can only be performed by qualified personnel who:

- Are licensed and/or satisfy state and local regulations.
- Have good knowledge of this manual and other related documents.
- A medium-voltage operator is required to obtain any Certifications for High-voltage Electrician.

Conventions

The symbols that may be found in this manual are defined as follows.

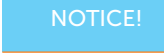
Symbol	Description
 DANGER	Indicates a hazardous situation which, if not avoided, will result in death or serious injury.
 WARNING	Indicates a hazardous situation which, if not avoided, could result in death or serious injury.
 CAUTION!	Indicates a hazardous situation which, if not avoided, could result in minor or moderate injury.
 NOTICE!	Provides tips for the optimal operation of the product.

Change History

Version 3.0 (2026-02-11)

Added "2.2.2 Product Type Identification", "2.3.1 Supported Power Grid", "13.1 Installation Video" for adding a new type of cabinet.

Updated "2.2 Major Parts Description", "7 Electrical Connection", "8 System Power-on", and "10.1 Power-off" for adding the new type of cabinet.

Updated "13.2 Requirements for OT/DT Terminal" for removal of the copper+aluminum washer note and related scenario, and standardization of the term "copper–aluminum bimetallic terminal".

Deleted Automatic mode and Forced mode of air conditioner .

Updated "Installation location" (Must be installed outdoors Changed to Recommended to be installed outdoors.)

Updated "Figure 4-5 Dimension of steel foundation" and "Figure 4-6 Detail description of steel foundation".

Updated "4.1 Installation Site Selection".

Updated "2.3.2 System Schematic Diagram".

Version 2.0 (2025-02-07)

Updated "10.1 EMS Setup".

Updated "2.3.2 System Schematic Diagram".

Added Concrete foundation.

Added "Steel foundation".

Version 1.0 (2024-12-31)

Updated "1 Safety".

Version 0.0 (2024-10-11)

Initial release

Table of Contents

1	Safety	1
1.1	General Safety	1
1.2	Device Safety.....	2
1.2.1	Cabinet Safety	2
1.2.2	Battery Safety.....	3
1.2.3	Air-cooled Chiller Safety.....	5
1.2.4	PCS Safety	6
1.2.5	Utility Grid Safety	7
1.3	Electrical Safety	7
2	Product Overview	10
2.1	Product Introduction.....	10
2.1.1	Functions and Features	10
2.1.2	Product Type Identification.....	11
2.1.3	Appearance and Dimension	12
2.2	Major Parts Description	14
2.2.1	Dimensions with Door Closed.....	14
2.2.2	Dimensions with Door Open.....	16
2.2.3	AC Distribution System	20
2.2.4	DC Side Battery System.....	22
2.2.5	Power Conversion System.....	25
2.2.6	Environmental Monitoring System.....	27
2.2.7	Fire Suppression System.....	28
2.2.8	Energy Management System.....	29
2.3	Operating Principle	31
2.3.1	Supported Power Grid.....	31
2.3.2	System Schematic Diagram	32
2.3.3	Working Mode.....	33
2.4	Typical Application Scenario	34
2.5	Graphical Symbols	35
3	Transportation and Storage	36
3.1	Transportation Requirements.....	36
3.1.1	Forklift.....	37
3.1.2	Hoisting	39
3.2	Storage Requirements.....	39
3.2.1	Cabinet Storage	39

3.2.2	Battery Storage.....	40
4	Preparation Before Installation.....	41
4.1	Installation Site Selection	41
4.1.1	Installation Foundation Requirements.....	43
4.1.2	Clearance Requirements	48
4.2	Tool Requirements.....	50
4.3	Additionally Required Materials	51
5	Unpacking and Inspection	53
5.1	Unpacking.....	53
5.2	Packing List.....	54
6	Mechanical Installation	57
6.1	Cabinet Handling.....	57
6.1.1	Crane Hoisting	57
6.1.2	Fork Handling	59
6.2	Cabinet Installation	60
6.3	Removal of Detector and Sensor Protective Covers.....	62
7	Electrical Connection	63
7.1	Grounding Connection	64
7.2	Grid Connection.....	66
7.3	Network Connection.....	74
7.3.1	Wireless Connection (4G).....	74
7.3.2	Wired Connection (Ethernet).....	76
8	System Power-on	80
8.1	Check Before Power-on.....	80
8.2	Powering on the System.....	81
9	System Login.....	84
9.1	EMS Setup	84
9.2	SolaXCloud App Login.....	89
10	Troubleshooting and Maintenance	90
10.1	Power-off	90
10.2	Troubleshooting.....	94
10.3	Maintenance.....	99
10.3.1	Maintenance Routine	99
10.3.2	Disassembly and Clean of Air Conditioner Filter	101
10.3.3	Maintenance of Battery Pack	102
11	Dispose of Wasted and Damaged Battery Pack	103

12	Technical Data	104
	12.1 TRENE-P100B215.....	104
	12.2 TRENE-B215	105
13	Appendix	106
	13.1 Installation Video	106
	13.2 Requirements for OT/DT Terminal	107
	13.3 How to Repaint the Cabinet.....	108
	13.3.1 Light Scratches & Small Areas of Stubborn Stains.....	108
	13.3.2 Deep Scratches and Large Areas of Stubborn Stains.....	111
	13.3.3 Logo & Pattern Damaged, Dents or Dings.....	113

1 Safety

1.1 General Safety

Before transporting, storing, installing, operating, using and/or maintaining the device, please carefully read and understand the document, and strictly follow the instructions and safety precautions given herein, as well as symbols affixed on the device. The safety instructions herein are only supplements to local laws and regulations.

The operator should not only abide by all safety precautions provided in the document, including but not limited to the "Danger" sign, "Warning" sign, "Caution" sign, and "Notice" sign, but also comply with relevant international, national and local laws, regulations, standards, guidelines and industry rules in the process of transportation, storage, installation, operation, and maintenance. SolaX will not assume any responsibilities for the loss caused by improper operation, or violation of safety standards for design, production and equipment suitability.

SolaX will not be liable for maintenance for possible device failure, device malfunction, or parts damage, nor will the company assume any liability to pay compensation for the possible physical and property damage resulting from the installation environment that does not meet the design requirements.

The device is well designed and tested to meet all applicable state and international safety standards. However, like all electrical and electronic equipment, safety precautions must be observed and followed during the installation of the device to reduce the risk of personal injury and to ensure a safe installation.

SolaX will not assume any responsibilities if any of the following circumstances occur, including but not limited to:

- Device damage due to force majeure, such as earthquake, flooding, thunderstorm, lighting, fire hazard, volcanic eruption, war, typhoon, tornado, etc.
- Device damage due to human cause or caused by strong vibrations from external factors before, during and after installation.
- Device used or operated against local policy or regulations.
- Failure to follow the operation instructions and safety precautions on the product and in this document.
- Installation and use under improper environment or electrical condition.
- Unauthorized modifications to the product or software.
- Device damage caused during transportation by the customer or the third party.
- Storage conditions that do not meet the requirements specified in this document
- Use of incompatible inverters or devices.
- Installation and commissioning operated by unauthorized personnel who are not licensed and /or satisfy state and local jurisdiction regulations.

1.2 Device Safety

To prevent personal injury or property damage from improper operation, please carefully read the following installation precautions before installation.

1.2.1 Cabinet Safety

DANGER!

- According to the local laws and regulations related to high-altitude work, operators must wear PPE, e.g., a helmet, safety belt, or waist harness, when they work at heights, while the other end of the harness must connect to a secure structure to prevent fall incidents.

WARNING!

- Please prepare tools that meet the requirements before installation, and check the number of tools after installation, to avoid leaving them inside the equipment.
- Please ensure that the cabinet has been thoroughly secured before operating it. Otherwise, it may cause personal injury or equipment damage due to tilting or collapsing the cabinet.
- Please ensure that the cabinet's vents and cooling system are working properly when it is running. If the vents are blocked, it will lead to overheating, and even equipment damage or fire hazard.
- Please ensure that the cabinet's vents and cooling system are kept away from heat sources.
- Do not drill holes in the device to avoid equipment failure.
- If the circumstances that may cause personal injury or equipment failure occur, such as, fluid flowing into the equipment, stop operation and power off immediately. Otherwise, it may cause a short circuit or damage.
- Do not open the cabinet doors on a rainy or high humid day ($\geq 80\%$ humidity). If the doors have to be opened on such days, please take proper protective measures.

CAUTION!

- Do not use a straight ladder. When electrical work is involved, a wooden ladder or an insulated ladder shall be used.
- The equipment shall not be used to provide a backup power source in the following circumstances:
 - a. Equipment related to life;
 - b. Sensitive precision instruments;
 - c. Home appliances will be faulty in the case of a power failure during operation.

NOTICE!

- The signs and messages on the labels and nameplates attached to the device need to be visible and clear.

1.2.2 Battery Safety

DANGER!

- Do not connect the positive and negative poles of a battery together. Otherwise, it may be short-circuited. This will result in an excessive flow of current and large quantities of energy for a short time, and then will cause battery leakage, smoke, the emission of flammable gases, thermal runaway, fire, or even an explosion. Therefore, the battery must be powered off before maintenance.
- If a battery is overheated, it will cause leakage, smoke, release of flammable gases, thermal runaway, fire, or even an explosion. Therefore, please ensure that the installation site shall be well ventilated and kept away from high temperatures.
- Do not dismantle, change, shake, drop, crush, impact, cut, penetrate with a sharp object, or any other ways to damage the battery. Otherwise, it may cause leakage, smoke, emission of flammable gases, thermal runaway, fire, or even an explosion.
- Do not mix different types or makes of the battery. Otherwise, it may cause leakage or rupture, resulting in personal injury or property damage.
- The battery electrolyte is toxic and volatile. Never get in contact with the leaked liquids or inhale gases in the case of the battery leakage or odor, and contact professionals immediately. The professional must wear PPE (including but not limited to safety glasses, safety gloves, gas masks, and protective clothing) before powering off the device, and then contact our company at once after removing the damaged battery.
- Normally, the battery will not release any gases. However, in the following situations: burnt, needle-pricked, squeezed, struck by lightning, overcharged, or subject to other adverse conditions that may cause battery thermal runaway, the battery may be damaged or an abnormal chemical reaction may occur inside the battery, resulting in electrolyte leakage or production of gases. If the battery needs to exhaust flammable gas, safe emission measures must be taken to prevent fire and device corrosion.
- Do not use damaged batteries, and ensure that the installation site must be well ventilated.

WARNING!

- Please read the document carefully before installation, operation and maintenance.
- Must arrange fire-fighting equipment in advance according to the local laws, regulations, and standards while installing and commissioning the device.
- Please check that there is no damage to the outer packaging before and after unpacking, and in the process of storage and transportation. The battery shall be correctly placed or stacked in accordance with the requirements stipulated on the labels to prevent damaging or scrapping the battery resulting from crushing or falling.

 **WARNING!**

- Must tighten screws securing cables and on the copper bars according to the torque information specified in the document, and check whether they are tightened periodically. For instance, whether there is any rust, corrosion, or any other foreign object on it, and then clean it up if any. Because the loose screw connections may result in excessive voltage drops and large currents, leading to generating a lot of heat and burning the battery.
- The battery should be charged in time after discharge, to prevent battery damage due to overdischarge. If a battery pack is stored for a long time, please periodically recharge it to protect it from damage according to the storage requirements specified in the document.
- Please charge the battery within the specific temperature range because the low temperature may result in a short circuit. Hence, do not charge it when the temperature is below the low limit of the operating temperature.
- Do not use the battery when you find a bulge, or dents on the battery housing, and contact the installer or professional maintenance personnel to dismantle and replace it. The damaged battery must be kept away from other devices and flammable and explosive articles, and do not contact it except for professionals.
- Before operation, ensure that there are no irritating or burning smells around the battery.
- Do not weld or grind near a battery. Because electric sparks or arcs may cause fires.
- Do not step, lead, stand, or set on the battery.

NOTICE!

Transportation requirements for battery:

- Relevant qualifications for the transport of dangerous goods must be obtained by the forwarding agent engaged in such businesses, and they must strictly abide by the local regulations for the transport of dangerous goods.
- Please check the battery before transportation. If a battery leaks, smells, or is damaged, do refuse to transport it.
- Please handle gently in the process of loading and unloading, transportation, and moving a battery to prevent bumping, and take effective moisture-proof measures to prevent personal injuries and battery damage.
- Unless otherwise specified, do not transport the batteries, which are classified as dangerous goods, together with food, medicine, or other additives on the same means of transport.

If the battery leaks electrolyte or any other chemical materials, the electrolyte leakage can lead to toxic gases. Therefore, do not contact with them at all times. In case of accidentally coming into contact with them, please do as follows:

- In case of inhalation: Leave the contaminated area immediately, and seek medical attention at once;
- In case of contact with eyes: Rinse eyes with running water for at least 15 minutes, and seek medical attention;
- In case of contact with skin: Wash the contact area thoroughly with soap, and seek medical attention;
- In case of ingestion: Induce vomiting, and seek medical attention.

NOTICE!

If a fire breaks out where the battery is installed, please do as follows:

- In case a battery is charging when the fire breaks out, provided it is safe to do so, press the emergency stop button and unplug the power cable;
- In case a battery is not on fire yet, use a water-based fire extinguisher or a carbon dioxide extinguisher to extinguish the fire;
- In case a battery catches fire, do not try to put it out, and evacuate immediately;
- A battery may catch fire when it is heated above 150°C/302°F. If the battery catches fire, please evacuate immediately since it will generate noxious and poisonous gases.

Recovery of damaged or wasted battery:

- Dispose of the damaged or wasted batteries according to local laws and regulations instead of placing them in the household trash or curbside recycling bins. Otherwise, it may cause environmental pollution or explosions.
- Ensure that the damaged or wasted batteries are not exposed to the following situations: high temperatures, high humidity, direct sunlight, or corrosive environments.
- Contact a battery recycling company to scrap the battery, which leaks electrolytes, or is damaged or expired.
- Please take protective steps to prevent battery short circuits before moving batteries.
- Please keep away from flammable material storage areas, residential areas, and other population centers when transporting and storing the damaged battery.

1.2.3 Air-cooled Chiller Safety

 WARNING!

- When the chiller is running, please do not touch the internal components of the chiller with your hands at will to avoid electric shock or injury from the fan blades.

 CAUTION!

- If severe vibration or abnormal sound occurs during running or debugging of the chiller, please stop all operations and immediately cut off the circuit switch for inspection.
- Do not allow liquids such as water to enter the terminal area of the device during installation and maintenance.
- Only when all the circuit switches are turned off and the internal control board no longer flashes the signal light, can you operate the device circuit and electronic devices, and you must wear anti-static gloves.
- The waste is hazardous. Please properly handle it, and avoid contact of the waste with soil or drainage systems.
- Coolant may cause irritation to eyes, skin, and throat. When handling, wear PPE and use only authorized tools.
- Do not heat the liquid cooling unit in an empty container since it may cause an explosion.

NOTICE!

- While injecting the liquid, if the injection process is interrupted manually, restart the process from the beginning when resuming.
- During injection, ensure that the hose in the coolant collection tank is fully submerged and maintains proper coolant flow.
- After completing injection and drainage, thoroughly flush the hoses of the inject machine to remove residual coolant.
- Use a coolant collection tank with a capacity of 20 liters or more, and keep it clean, dry and free from contaminants.

NOTICE!

If the coolant leaks, please avoid contact with it at all times. In case of accidentally coming into contact with it, please do as follows:

- In case of contact with eyes: Rinse eyes with running water for at least 15 minutes, and seek medical attention;
- In case of contact with skin: Wash the contact area thoroughly with soap, and seek medical attention.

1.2.4 PCS Safety

 **DANGER!**

- Only operate the inverter if it is in a technically faultless condition. Operating a faulty inverter may lead to electric shock or fire.
- Do not attempt to open the enclosure without authorization from SolaX. Unauthorized opening of the enclosure will void the warranty and can result in lethal danger or serious injury due to electric shock.
- Make sure that the inverter is reliably grounded before any operation to prevent the risk of electric shock causing lethal danger or serious injury.
- Only qualified personnel can perform the installation, wiring, maintenance of the inverter by following this document and the related regulations.

 **WARNING!**

- Operators must wear PPE while installation and maintenance of the device.
- During operation, avoid touching any parts of the PCS.
- Never connect or disconnect the AC and DC connector while the inverter is running.
- Prior to conducting any maintenance, turn off the AC and DC power and disconnect them from the inverter. Wait for 15 minutes to fully discharge the energy.
- Avoid touching the inverter while it is running, as it becomes hot during operation and may cause personal injuries.

NOTICE!

- The inverter has an integrated Residual Current Monitoring Unit (RCMU). If an external Residual Current Device (RCD) is required by local regulations, verify the type of RCD required. It is recommended to use a Type-A RCD with a rating of 300 mA unless a lower value is required by the specific local electric codes. When required by local regulations, the use of an RCD type B is permitted.

1.2.5 Utility Grid Safety

NOTICE!

- Only connect the PCS to the grid with the permission of the local utility grid company.

1.3 Electrical Safety

 DANGER!

- Please make sure that the unit is free from any damage before the electrical connection.
- Do not modify, change, or dismantle the device, do not change the power-on and power-off sequences and the installation procedure written in the document, and please properly and correctly operate it.
- Do not power on the device during installation. Otherwise, it may cause a fire, personal injury, or device damage.
- Must remove earrings, rings, bracelets, watches, and any other metal jewelry before operation, to avoid electrical shock, burns, or even death.
- During operation, special insulated tools must be used to avoid electric shock or short circuit failure. The insulated tools' voltage ratings must exceed the system voltage ratings. Please refer to "12 Technical Data" for system information.

 WARNING!

- Please wear PPE, such as, protective clothing, insulating shoes, goggles, safety helmets, insulating gloves, etc., when conducting electrical wiring.
- Do not touch the power supply equipment directly, or through conductors or damp objects.
- Do not touch the parts of the equipment of which warning signs are attached, to avoid personal injury or device damage.

 CAUTION!

- Do not power on the device until it has been installed and confirmed by professionals.
- In the event of a fire, evacuate immediately and call the local fire services.

NOTICE!

- Please operate according to the safety code for power station.
 - Before installation, it is necessary to set up temporary safety fences or warning lines and hang warning signs in the operation area, to prohibit non-staff from entering here.
 - Please make sure that the equipment and its associated switches are off before connecting and disconnecting power cables.
-
- Please check whether the protective housing and insulating sleeve for an electrical component have been installed correctly after finishing installation, to avoid electric shock.
 - Must turn off the output switch of the power supply equipment when maintaining its electrical terminal device and power distribution device.
 - If the device is required to be powered off during troubleshooting and diagnosis, please do as the following procedure: power off > electricity testing > connecting grounding cable > hanging warning signs and setting up guardrails.
 - Must hang up "Do Not Switch On" warning signs on the relevant switches or circuit breakers before completing maintenance, to prevent power connection. Do not switch on before the fault is solved.
 - Do not use water, alcohol, oil, or other solvents when cleaning electrical components inside and outside the device.

NOTICE!

Grounding Requirements:

- The device's grounding impedance shall meet the requirements of local electrical safety standards.
- The equipment shall be permanently connected to a grounding wire within the building's electrical system. Please check whether the device is reliably grounded before operation. The grounding cable should be removed last while dismantling and maintaining the device.
- Do not start the device if it is not fitted with a grounding conductor.
- All acts against the grounding conductor are prohibited.
- If the device is equipped with a three-pronged socket, make sure that the ground prong is reliably grounded.
- For the device that may generate large contact currents, please make sure that the grounding terminal on the housing has been grounded before powering on, to avoid electric shock.

NOTICE!**Cable Requirements:**

- When deciding the wire diameter, and connecting or wiring cables, follow the local laws, regulations, and codes to ensure safety.
 - When external conditions (e.g., placement method, ambient temperature, etc.) change, the cable type must be verified according to IEC-60364-5-52 or local laws, regulations and standards. For instance, whether the cable's current-carrying capacity meets the requirements.
 - Before connecting power cables, please make sure that the cable labels are correctly labelled and the cable terminals are well insulated.
 - Do not loop and twist cables while conducting electrical wiring. If the length of the power cable is not enough, please replace it instead of joining or welding. Ensure that all the cables of the correct type and size are fully connected and well insulated, and the edges of cable slots and crossing holes are smooth.
-
- It is recommended to bundle similar cables with cable ties, to ensure that the inside of the device is neat and tidy and to avoid cable jacket damage.
 - Please use fireproof mud to seal the threading openings immediately after finishing wiring, to avoid the entry of water vapour or small animals.
 - Cables should be kept away from heaters or other heat sources, because a high temperature environment may result in aging and damage to cable insulation.

2 Product Overview

2.1 Product Introduction

Featuring an all-in-one design, the liquid cooling energy storage system integrates high performance PCS, BMS, high-capacity battery packs, smart EMS, and advanced air cooling unit and fire protection mechanism in one cabinet. As a smart outdoor energy storage system, it is easy to install and expand, and is especially applicable to industrial and commercial scenarios.

2.1.1 Functions and Features

Functions

- The TRENE energy storage system consists of an energy conversion module and an intelligent air-cooled lithium-ion battery system, which can store and release power according to the control commands issued by the built-in EMS.

Features

- TRENE-P100B215 includes the AC distribution system, DC side battery system, power conversion system, environmental monitoring system, fire suppression system, and energy management system. It is characterised by safety, intelligence, reliability, and economy.
- It is equipped with multiple safety protection measures. Built-in over-voltage, over-current, over-temperature and other protection functions, as well as fireproof materials and level 4 fire safety protection system, can detect and respond to potential live risks in time, and effectively control the speed of fire spread.
- Advanced EMS intelligent control of energy storage system operation strategy, independent implementation of intelligent scene switching according to the market price of electricity help to improve the operational efficiency of the entire energy storage system and shorten the investment recovery cycle.
- Supports three-phase unbalanced applications and rapid expansion to ensure more reliable power supply.

2.1.2 Product Type Identification

This model is available in two types (Type A and Type B). Before starting work, open the door and identify the type by checking the distribution box located inside the cabinet.

Type A product

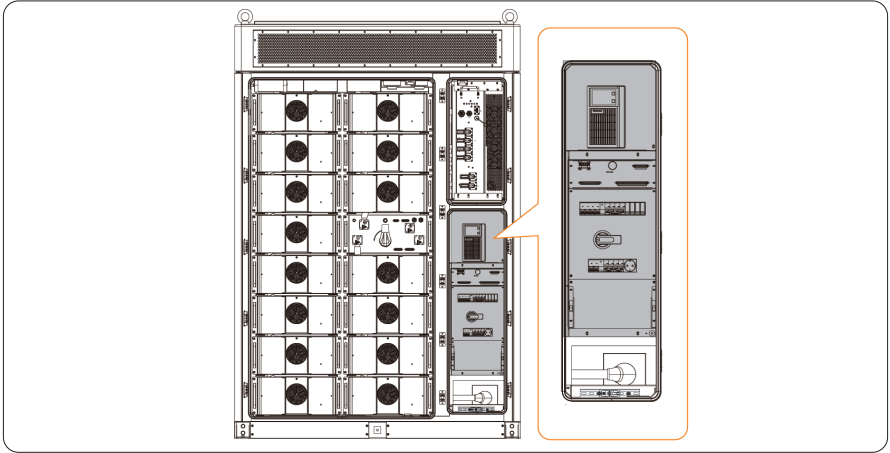

Figure 2-1 Type A product appearance

Type B product

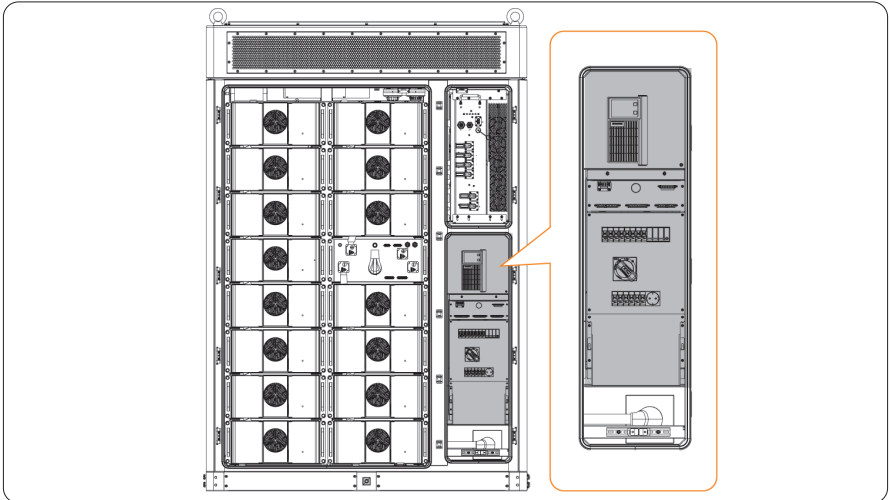

Figure 2-2 Type B product appearance

2.1.3 Appearance and Dimension

Angle supports installed at front and rear sides

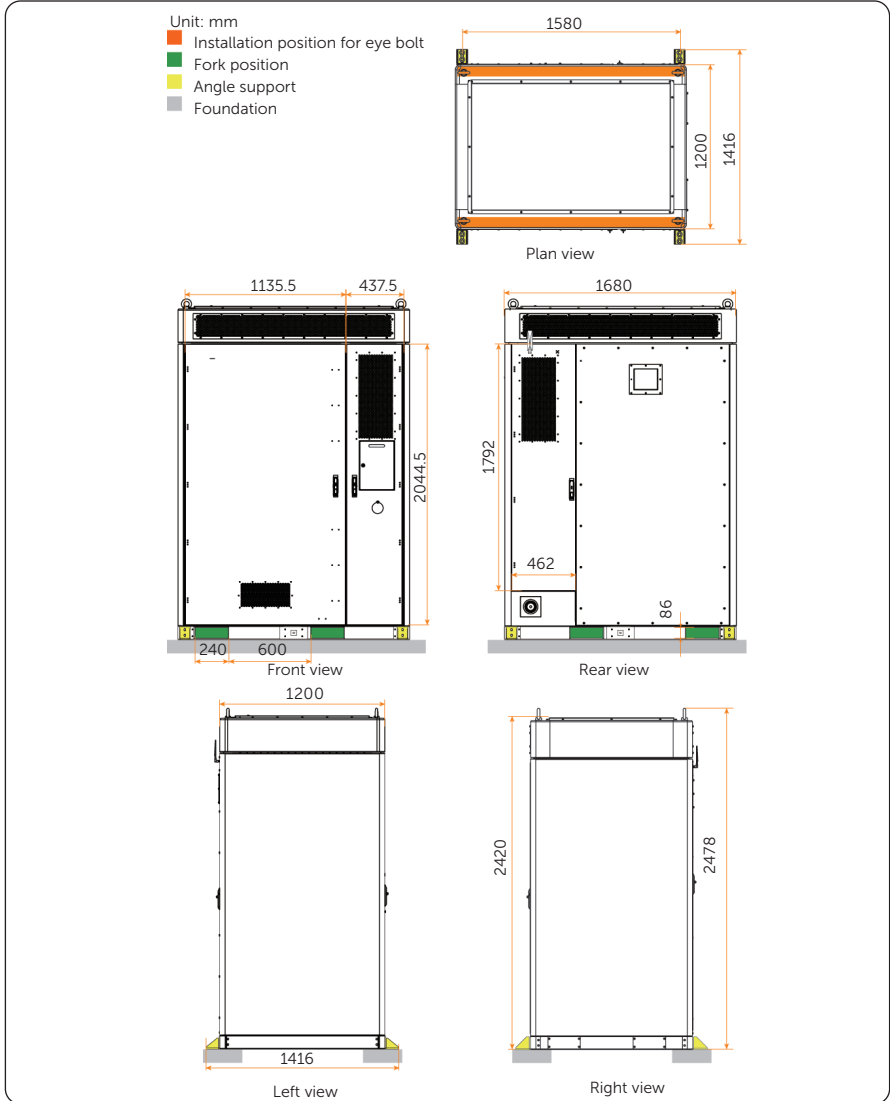

Figure 2-3 Appearance and dimension

Angle supports installed at left and right sides

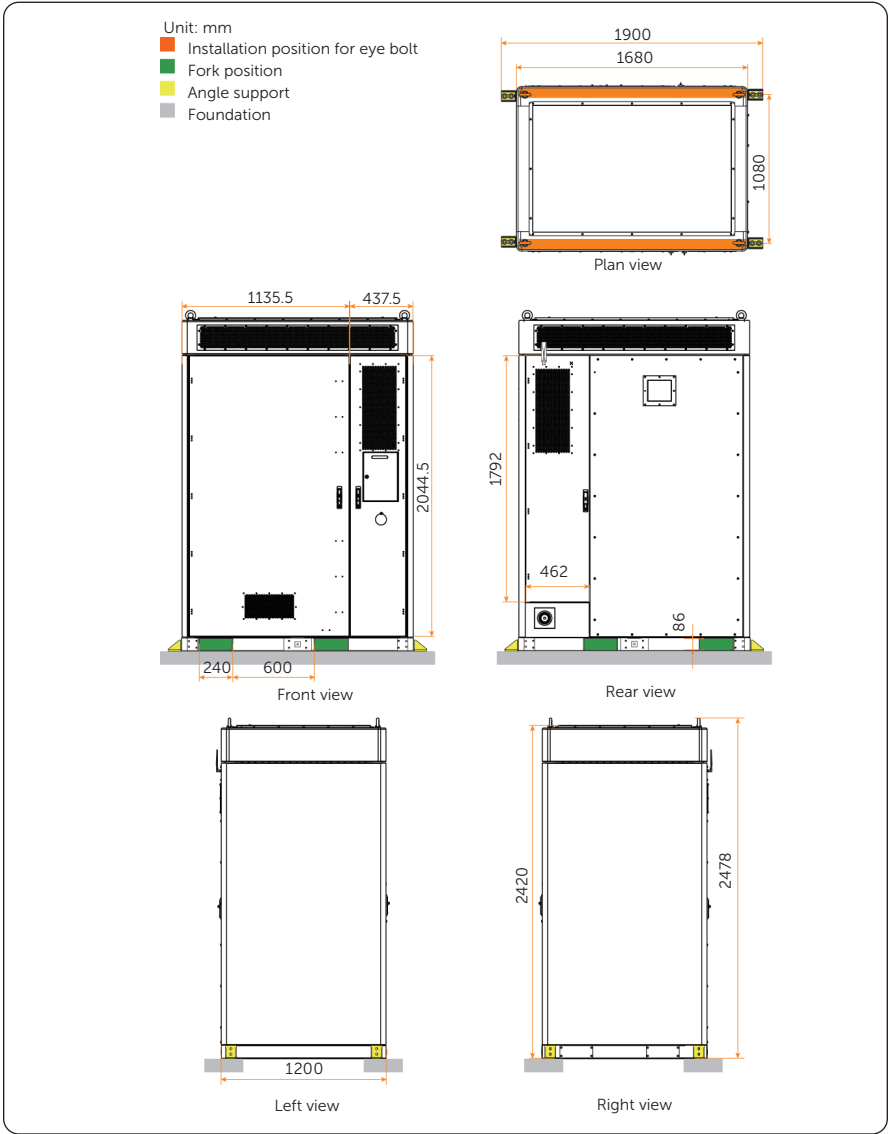

Figure 2-4 Appearance and dimension

2.2 Major Parts Description

2.2.1 Dimensions with Door Closed

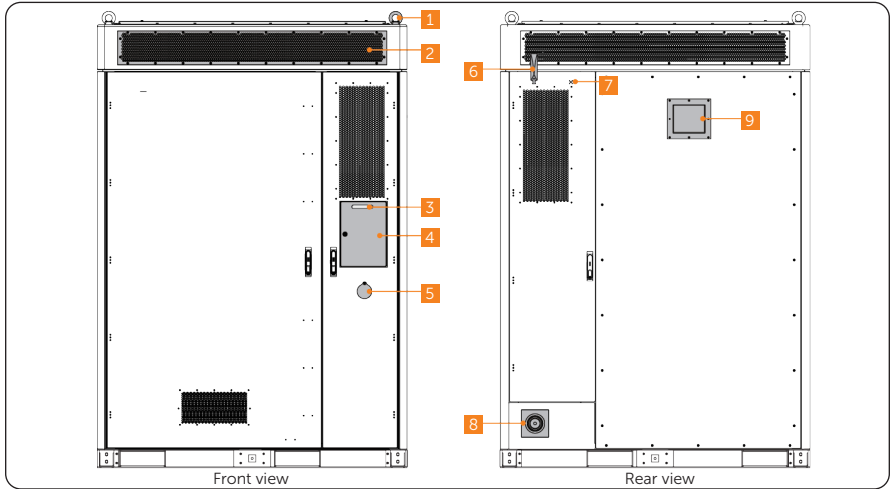





Figure 2-5 Parts description (with door closed)

Table 2-1 Parts description

No.	Item	Description
1	Eye bolt	Material lifting applications.
2	Air conditioner	Energy storage system air conditioner.
3	LED light	To display status information of all processes running on the system. For description, see " Table 2-2 LED indicator description ".
4	Display screen	To display information of the whole system.
5	Emergency stop button	To shut down the system in emergency circumstances.
6	Antenna	4G antenna for expanding data transmission.
7	A reserved antenna port	To connect wireless meter.
8	Fire hose nozzle	To connect the water supply sources.
9	Expansion-proof valve	To exhaust the combustible gas out of the cabinet.

Table 2-2 LED indicator description

Status		Description
Solid yellow light		In standby
Solid green light		In operation
Solid red light		System failure

2.2.2 Dimensions with Door Open

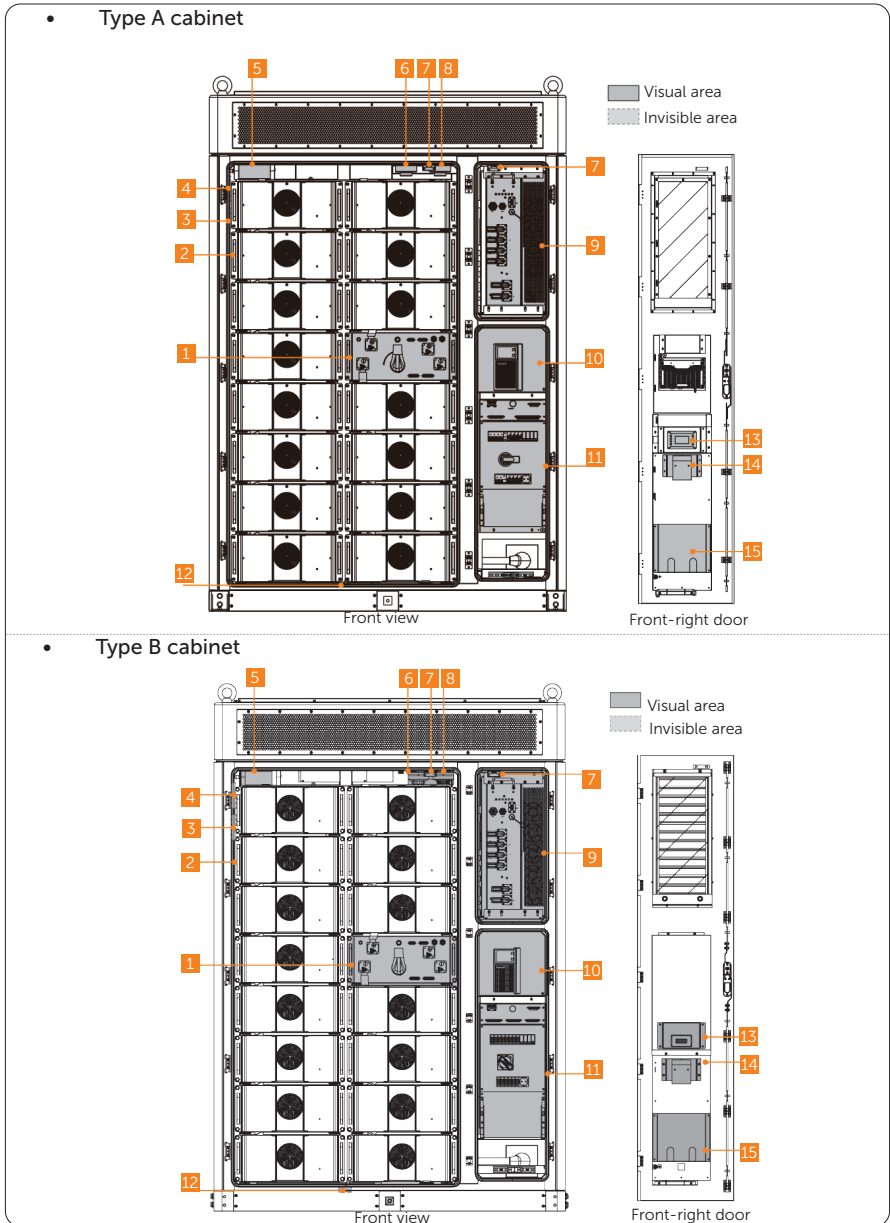

Figure 2-6 Parts description (with door open)

Table 2-3 Part description

No.	Item	Description
1	High-voltage box	To collect current and voltage information on battery tower, and control the charge and discharge of the battery pack.
2	Battery pack	/
3	Temperature and humidity sensor	To measure temperature and humidity.
4	CO detector	To detect CO gases.
5	Automatic fire sprinkler	To control or suppress the spread of fire.
6	Temperature sensor	To detect temperature.
7	Door sensor	To alert you when the door is open.
8	Smoke detector	To detect smoke.
9	PCS	/
10*	Control area	Including IO module, EMS, UPS, and more.
11	Distribution box	To distribute AC power for the energy storage system.
12	Water sensor	To detect water level based on the principle of potential difference between the two electrodes.
13	Control panel of air conditioner	To monitor the air conditioner and show relevant parameter.
14	Audible and visible alarm	To alert you when abnormal conditions (such as high temperature or smoke) occur.
15	File pocket	To put documents.

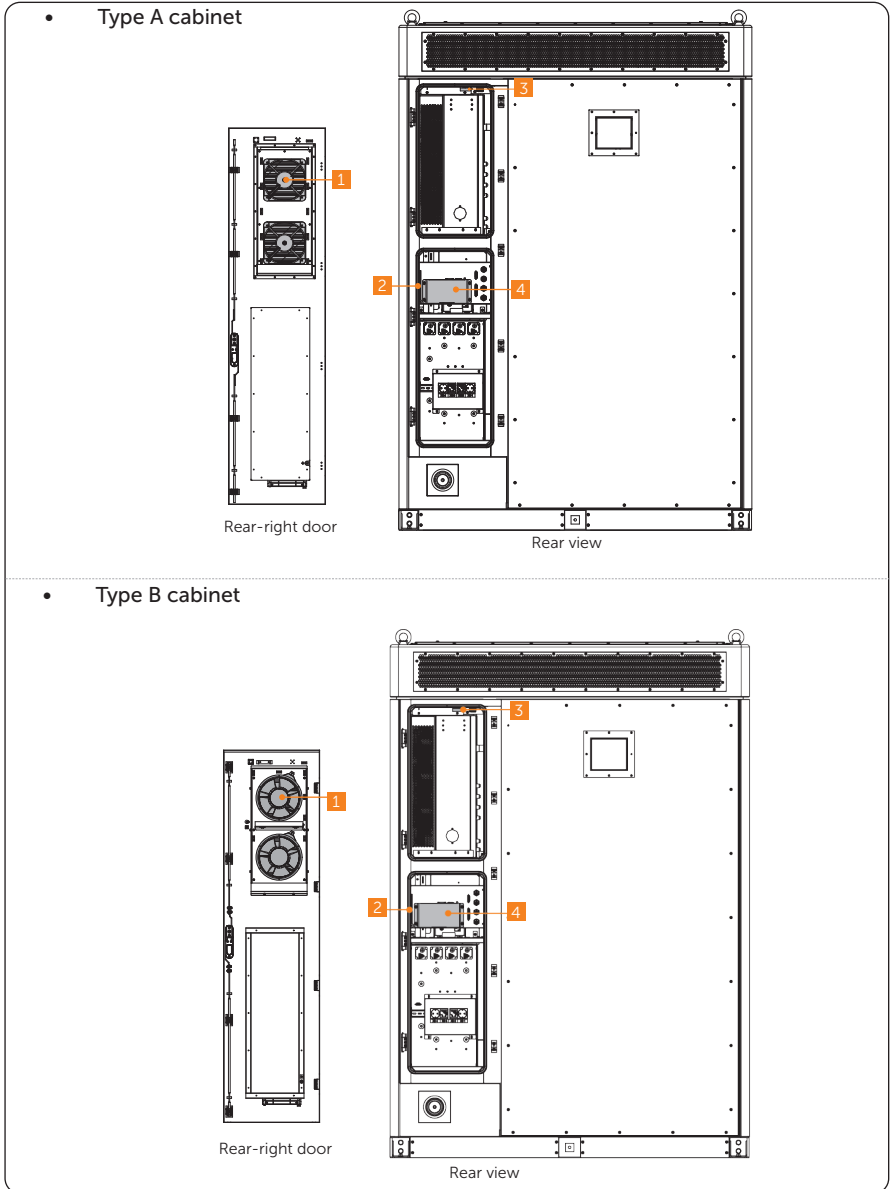

Figure 2-7 Parts description (with door open)

Table 2-4 Parts description

No.	Item	Description
1	Fan	To improve air circulation and dissipate heat when the temperature rises.
2	Switch	/
3	Door sensor	To alert you when the door is open.
4	EMS	An energy management system.

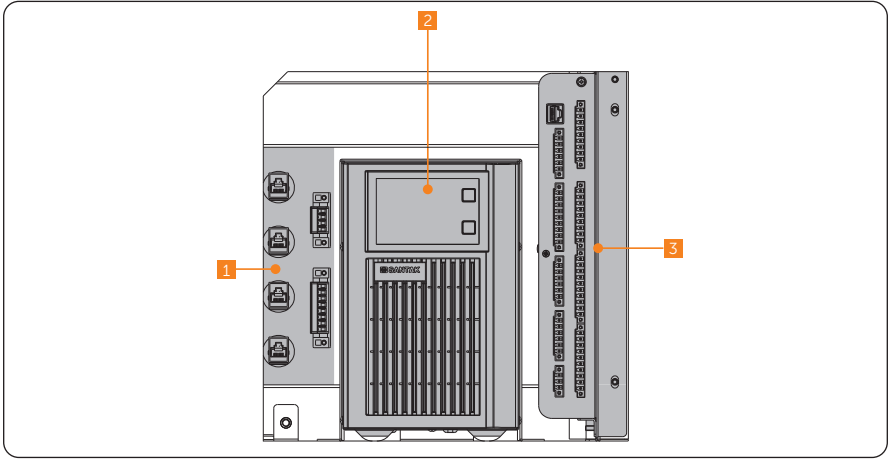

Figure 2-8 Parts description (control area)

Table 2-5 Parts description

No.	Item	Description
1	Ports	To achieve parallel connection.
2	UPS	To provide backup power to ensure that the device is in a normal operating condition.
3	IO module	To collect signal and control other modules.

2.2.3 AC Distribution System

Distribution box

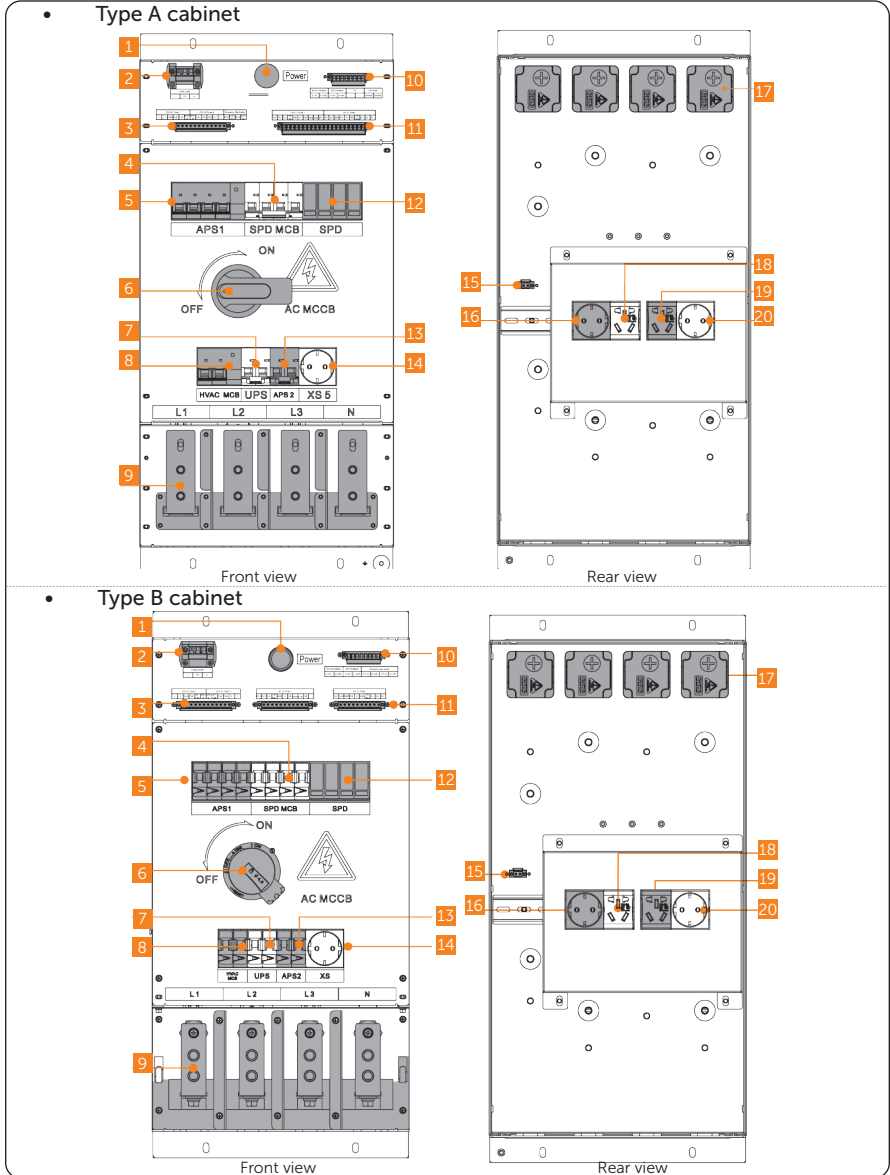

Figure 2-9 Distribution box

Table 2-6 Description of front panel

No.	Item	Description
1	LED indicator	To show the power status: With the disconnecter set to ON , the power indicator shows solid green when on and off when disconnected.
2	Power supply port for air conditioner	To connect to the air conditioner.
3	220 V power supply Port for controlling emergency stop switch	Provides 220 V power for other devices in the cabinet. To manually turn off AC side for emergency.
4	SPD maintenance breaker	/
5	Auxiliary power breaker of High-voltage box	/
6	Disconnecter	A switch for AC side.
7	UPS breaker	To protect UPS breaker.
8	Air conditioner/liquid cooling unit on/off breaker	/
9	GRID IN wire connector	Port for connecting to power grid.
10	Circuit breaker's electrical control signal	To remotely turn off AC power for emergency.
11	24 V power supply port	To provide power supply for the devices inside the cabinet.
12	Current terminal	To connect to the grid.
13	ASP2	/
14	XS5 Socket	To connect user's PC or be as a reserved socket.
15	220 V port	To connect user's wireless meter.
16	XS EMS	To connect user's EMS.
17	Grid out wire connector	For AC side.
18	XS1 Socket	A reserved power socket.
19	XS2 Socket	A reserved power socket.
20	XS UPS	To provide power supply for UPS.

2.2.4 DC Side Battery System

High-voltage box

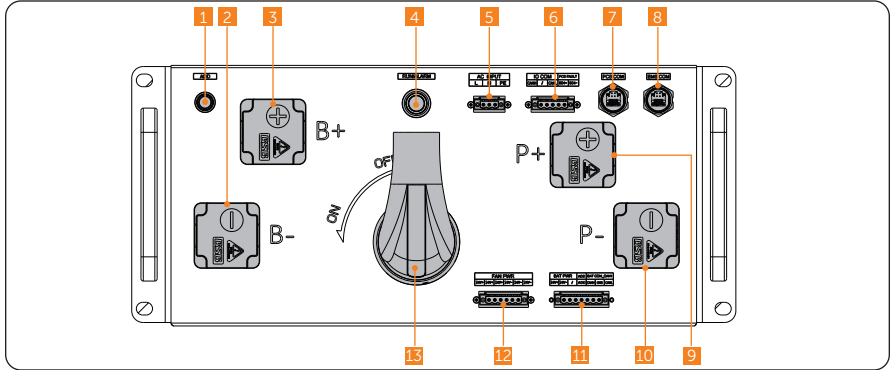





Figure 2-10 Front panel

Table 2-7 Description of front panel

No.	Item	Description
1	ADD button	To assign address.
2	Negative output port	To connect to the negative terminal of the battery pack.
3	Positive output port	To connect to the positive terminal of the battery pack.
4	Power button/LED status light	To start up or shut down system. For the LED indicator description, see " Table 2-8 LED indicator description ".
5	220 V AC input terminal block	To connect distribution box's CZ1.
6	Communication terminal block (for IO module)	To connect the IO module's CAN port and dry contact of the inverter.
7	Communication port (for PCS)	To connect the communication port of the PCS.
8	Communication port (for EMS)	To connect the communication port of the EMS.
9	P+ port	To connect the positive terminal of the PCS.
10	P- port	To connect negative terminal of the PCS.

No.	Item	Description
11	Terminal block (for battery pack)	To connect battery pack's communication cable and power cable.
12	Terminal block (for fan)	To connect to the power cable of the fan.
13	Disconnecter	To disconnect the device on the DC side.

Table 2-8 LED indicator description

Status		Description
Flashing green light		In operation
Solid green light		Ready in off state
Solid red light		System failure

Battery pack

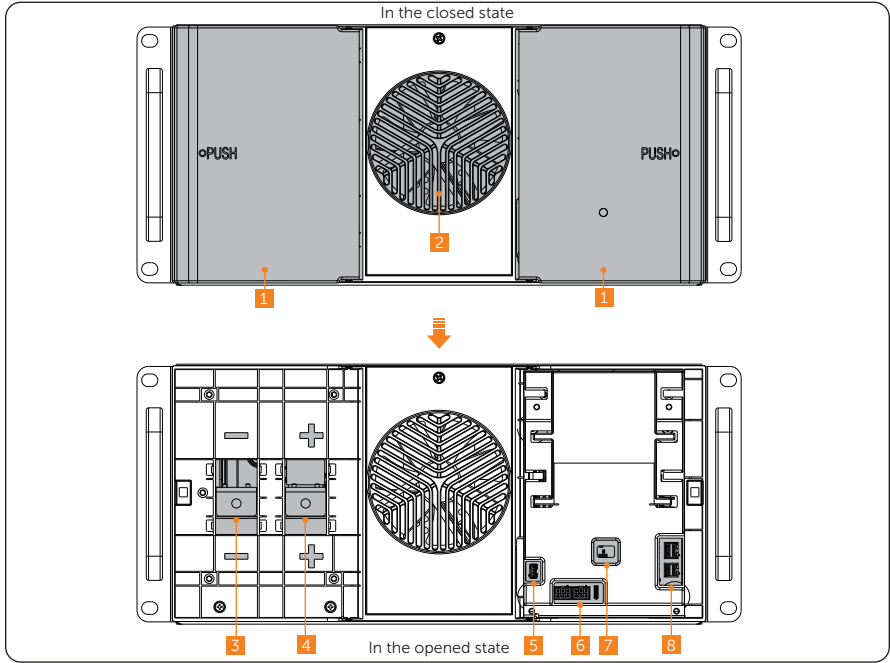

Figure 2-11 Front panel

Table 2-9 Description of front panel

No.	Item	Description
1	Left/right door	Please open the door while wiring.
2	Fan	To keep components cool in the cabinet.
3	Negative terminal	To connect negative terminal of high-voltage box or battery pack.
4	Positive terminal	To connect positive terminal of high-voltage box or battery pack.
5	Connection port (for fan)	To connect the fan.
6	Power connector (for fan)	To provide power to the fan.
7	LED status light	To display the running status of BMS.
8	Communication port	To connect communication cable.

Table 2-10 LED indicator description

Status		Description
Flashing green light		In operation

2.2.5 Power Conversion System

PCS

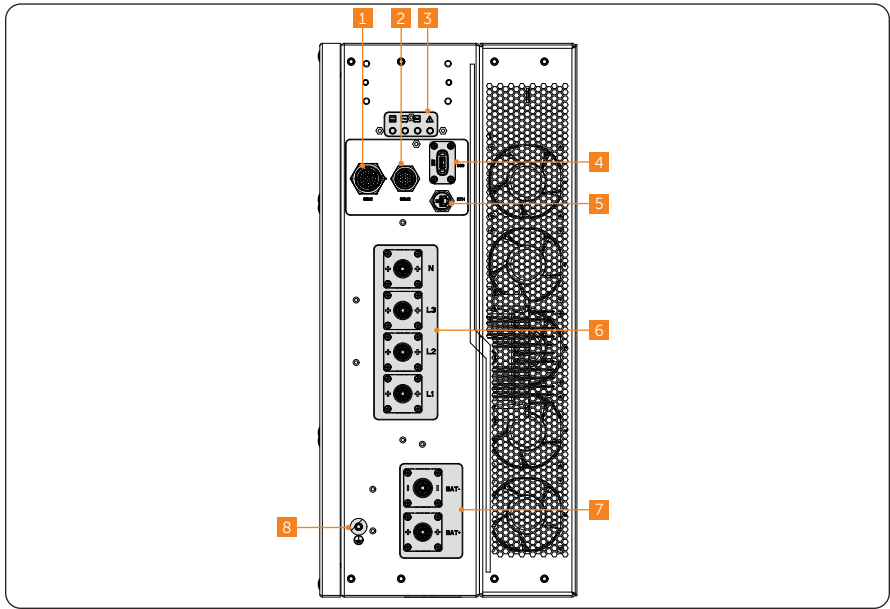



















Figure 2-12 Terminals of PCS

Table 2-11 Description of terminals

No.	Item	Description
1	COM1	COM 1 communication terminal.
2	COM2	COM 2 communication terminal.
3	LED light	To display the operation state.
4	USB	USB terminal.
5	ETH	ETH terminal.
6	N/L3/L2/L1	Grid connection terminal.

No.	Item	Description
7	BAT	Battery connection terminal.
8	/	Ground connection point.

Table 2-12 LED indicator description

LED indicator	Status	Definition
 DC		Light on PCS on-grid operation.
		Blinking slow (every 1.4 s) BMS failure.
		Blinking fast (every 0.3 s) When the red light is on, there is a DC side fault of the PCS. When the red light is off, the DC side battery status of the PCS is normal.
		Light off DC not connected on battery side.
 AC		Light on PCS on-grid operation.
		Blinking fast (every 0.3 s) When the red light is on, there is a fault on the AC side of the PCS. When the red light is off, the AC side grid status of the PCS is normal.
		Light off Grid not connected.
 COMM		Light on Monitoring communication normal, BMS communication normal.
		Blinking slow (every 1.4 s) BMS communication abnormal.
		Blinking fast (every 0.3 s) Monitoring communication abnormal.
 FAULT		Light on The PCS is in the fault state.
		Blinking The PCS is in the aging mode.
		Light off The PCS is normal.

2.2.6 Environmental Monitoring System

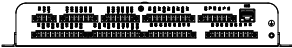
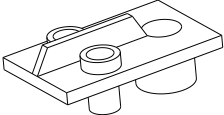
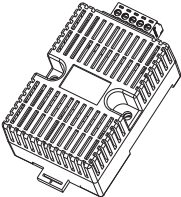
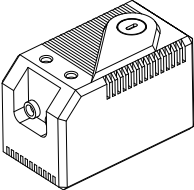
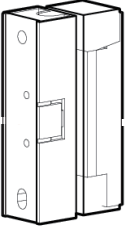
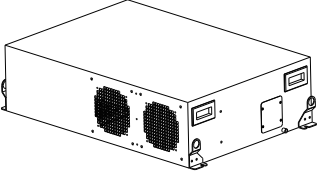
Item	Figure
IO module	 A long, thin printed circuit board (PCB) populated with numerous integrated circuits, resistors, and other electronic components. It has a multi-pin connector on one end and a small circular component on the other.
Water sensor	 A small, rectangular component with a flat top surface and two cylindrical protrusions on the bottom. The top surface has a circular opening and some internal wiring or components visible.
Temperature and humidity sensor	 A rectangular component with a complex, multi-layered top surface. It features a central circular opening and several smaller openings or ports. The bottom has a series of pins or a connector.
Temperature control switch	 A rectangular component with a textured top surface. It has a circular opening on the front face and a series of pins or a connector on the bottom. The side has a series of small rectangular openings.
Door sensor	 A vertical rectangular component with a central rectangular opening. It has several small circular openings on the side and a small rectangular component at the bottom.
Air conditioner	 A rectangular unit with a textured front face. It has two large circular openings on the left side and a smaller rectangular opening on the right. There are also some electrical connectors or ports on the bottom right.

NOTICE!

- Please refer to "11.3.2 Disassembly and Clean of Air Conditioner Filter" when it's time to clean or replace the air conditioner filter.

2.2.7 Fire Suppression System

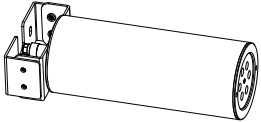
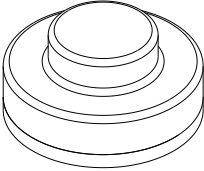
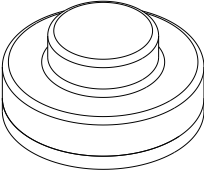
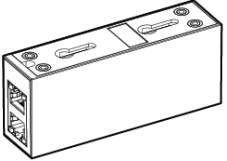
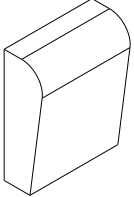
Item	Figure
Automatic fire sprinkler	
Temperature sensor	
Smoke detector	
CO detector	
Audible and visible alarm	

NOTICE!

- Before use, remove the protective covers from the temperature sensor and smoke detector.

2.2.8 Energy Management System

EMS

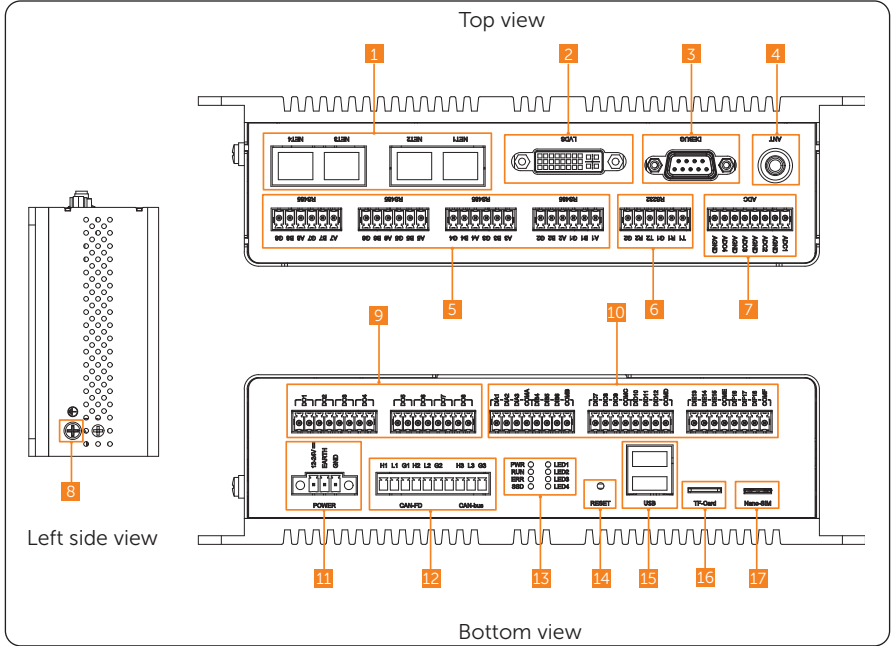

Figure 2-13 Appearance of the EMS

Table 2-13 Description of appearance

Position	Area	Item	QTY	Description
Top		1 Ethernet terminal (NET)	4	<ul style="list-style-type: none"> NET1: Reserved NET2: Connected to the computer for commissioning NET3: Connected to batteries NET4: Connected to the router for network
		2 LVDS terminal	1	Reserved
		3 Debug terminal (DEBUG)	1	Reserved
		4 Antenna socket (ANT)	1	For expanding signal transmission
		5 RS485 terminal	8	<ul style="list-style-type: none"> 1-5: Reserved 6: Connected to other grid-connected inverter 7: Reserved 8: Only connected to the meter
		6 RS232 terminal	2	Reserved
		7 ADC terminal	4	Reserved
Left side		8 Earthing terminal	1	For device earthing
		9 DO terminal	8	Reserved
		10 DI terminal	18	DIA1–DIA3 and COMA, DIB4 and COMB: Dry contact DIB5–COMF: Reserved
		11 Power supply (POWER)	1	12 Vdc–24 Vdc
		12 CAN terminal	3	2 × CAN-FD, and 1 × CAN-bus
Bottom		13 Indicators	8	<ul style="list-style-type: none"> Power status (PWR) Running status (RUN) Error (ERR) SSD status (SSD) LED 1–LED4: Reserved
		14 Reset button (RESET)	1	For device resetting
		15 USB socket (USB)	2	For device updates
		16 TF card socket (TF Card)	1	For firmware programming
		17 Nano-SIM card socket (Nano-SIM)	1	For 4G communication

2.3 Operating Principle

2.3.1 Supported Power Grid

Wiring configurations vary depending on the local grid system. The diagrams below illustrate TT, TN-S, and TN-C-S systems. For other grid types, consult SolaX to confirm compatibility.

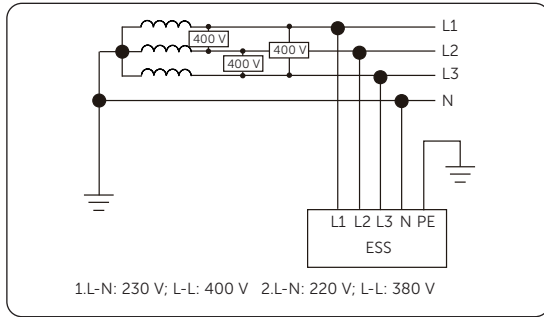

Figure 2-14 Supported power grid-TT

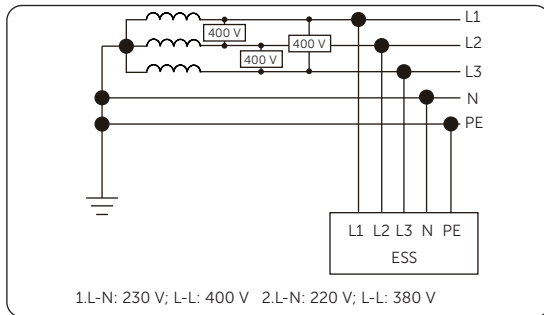

Figure 2-15 Supported power grid-TN-S

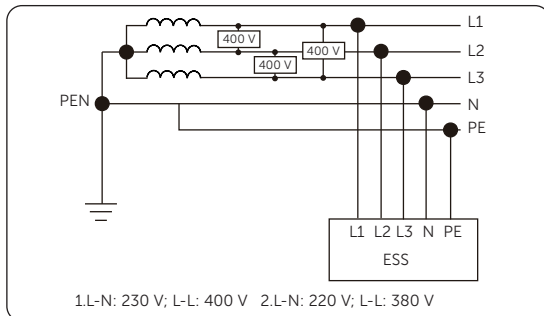

Figure 2-16 Supported power grid-TN-C-S

2.3.2 System Schematic Diagram

The system schematic diagram label is located on the back of the front-left door. For its exact position and details, refer to the figures below.

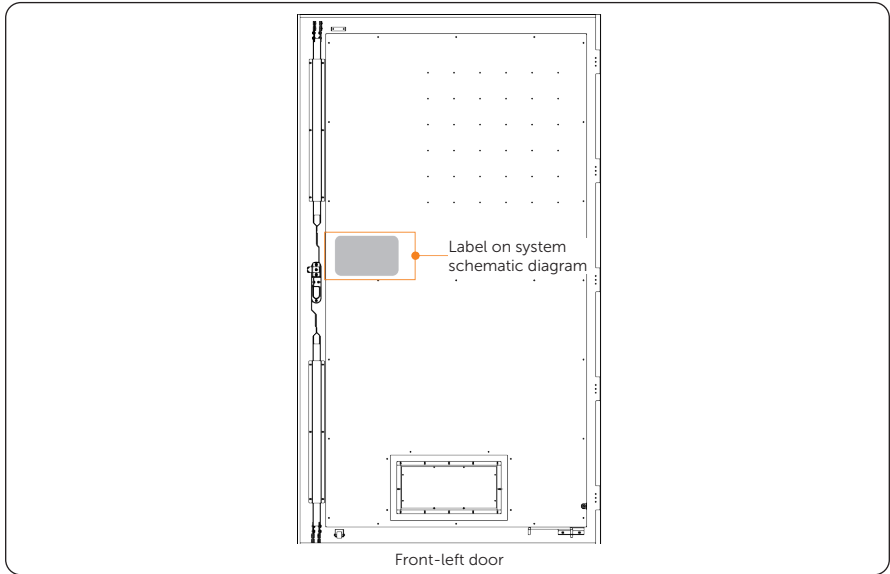

Figure 2-17 Label position

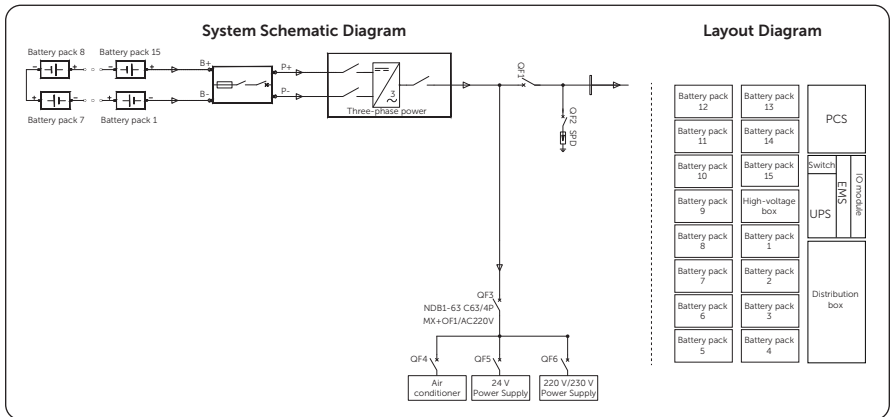

Figure 2-18 System Schematic Diagram

NOTICE!

- In an off-grid situation, the current will vary due to the types of electrical loads. The common electrical load can be classified into following types, resistive load, inductive load, capacitive load, half-wave load, etc. Therefore, the types of electrical loads shall be fully considered when designing and configuring a system. In the case of a half-wave load, the load power shall not exceed 1 kW; in the case of an uncertain electrical load, please contact the supplier for evaluation of output supply to special loads.

2.3.3 Working Mode

The air cooling energy storage system offers 3 working modes: charging, discharging and standby, and can store and release energy according to EMS commands.

States	Description
Charging	The EMS controls the PCS to charge the battery and store excess energy in the battery.
Discharging	When the grid is insufficient to supply the load, the system needs to control the battery to supply the load, in which case the energy stored in the battery is converted by the PCS to be used by the load.
Standby	Power on without performing work.

2.4 Typical Application Scenario

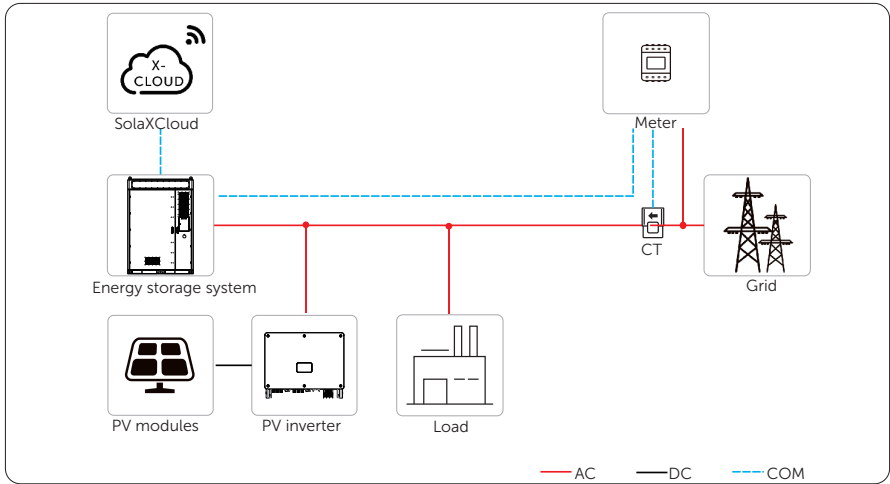

Figure 2-19 System overview diagram

NOTICE!















- An external communication cable should have shielding function.

Table 2-14 System item description

Item	Description
Energy storage system	ALL-IN-ONE intelligent outdoor energy storage system.
Meter/CT	The meter/CT is used for import/export or consumption readings, and manages the battery charge/discharge accordingly for smart energy management applications.
Grid	400 V/230 V and 380 V/220 V grid are supported.
PV Inverter	The PV inverter converts the direct current (DC) generated by solar panels into alternating current (AC) that is compatible with the power grid, and to facilitate the flow of electricity, thereby maximizing the efficiency of solar energy utilization and providing grid support.
SolaXCloud	SolaXCloud is an intelligent, multifunctional monitoring platform that can be accessed either remotely or through a hard wired connection. With the SolaXCloud, the operators and installers can always view key and up-to-date data. Commercial platform can be connected through EMS1000 connection (EMS1000 is integrated into the cabinet).

2.5 Graphical Symbols

Table 2-15 Symbol description

Symbol	Description
	CE mark of conformity.
	TUV certification.
	Protective conductor terminal.
	Earth (ground) terminal.
	Caution, hot surface. The enclosure temperature may be high while running. Therefore, do not contact to avoid scalding.
	Danger, electric shock. Do not touch the device after it is powered on. Otherwise, an electric shock may occur.
	Danger. Due to possible risks, do not touch the device after it is powered on.
	Observe enclosed documentation.
	The device cannot be disposed together with the household waste.
	Do not operate the system until it is isolated from mains and battery.
	Danger of high voltage. Do not touch live parts for 15 minutes after disconnection from the power sources.
	The battery system must be disposed of at a proper facility for environmentally-safe recycling.
	The battery pack may explode. The rechargeable battery can become hot during operation. Avoid touch during operation.
	Keep the device away from children.
	Keep the device from open flames or ignition sources.

3 Transportation and Storage

3.1 Transportation Requirements



- Please be careful to avoid physical collisions during transportation. Do not place the equipment upside down, be exposed to water, etc., which may result in equipment damage, or even a fire or an explosion.

NOTICE!

- Please strictly comply with the transportation requirements of the warning signs on the packaging and equipment.
- To reduce product damage caused by shocking, tilting or impacting during transportation, it is recommended to consider sea or road (with better conditions) transport instead of rail and air transports.
- Relevant qualifications for the transport of dangerous goods must be obtained by the forwarding agent engaged in such businesses, and they must strictly abide by the local regulations for the transport of dangerous goods. Please check the battery before transportation. If a battery leaks, smells, or is damaged, do refuse to transport it.

3.1.1 Forklift

- Please confirm that the forklift's load-bearing capacity shall be ≥ 5 t before using it.
- The forklift should meet the following requirements: length of fork blade > 1400 mm, width of fork blade between 610 mm and 860 mm, and thickness of fork blade between 20 mm and 90 mm.

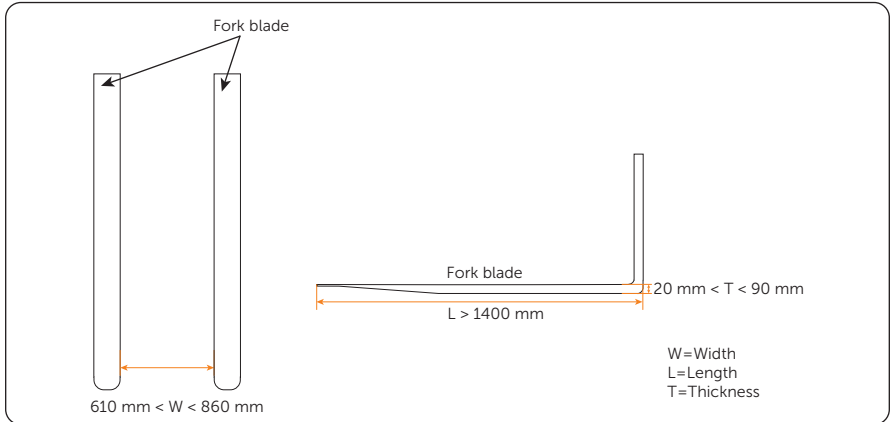

Figure 3-1 Forklift requirements

- Before moving the device, please pay attention to the center of gravity position of the load, and fully secure the load on the forklift by securing measures, such as ropes or bindings. In addition, please designate a person to supervise for safety concerns during transportation.
- Before unpacking, please accurately insert the fork blade into the fork holes on the carton when moving the device.

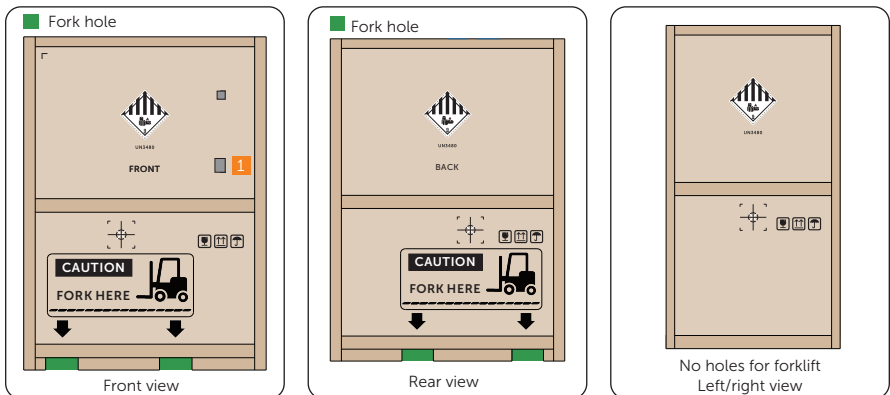

Figure 3-2 Carton fork holes

- The cabinet is equipped with an anti-tilt indicator. If the indicator is red upon receipt, the cabinet shall be considered to have experienced severe transportation impact. Do not install the cabinet and contact the supplier.

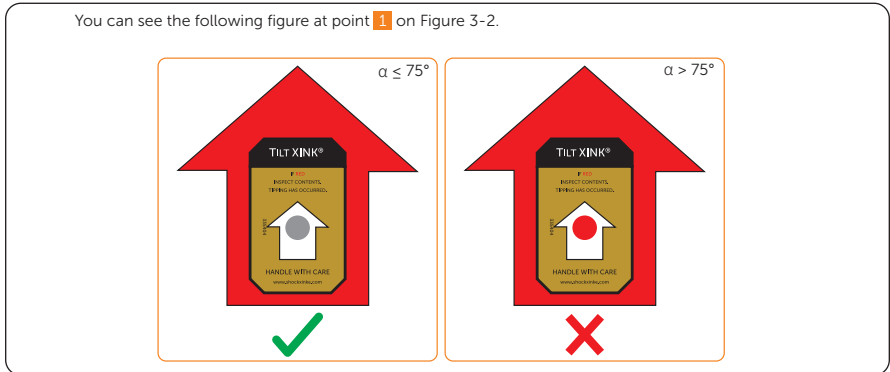

Figure 3-3 Anti-tilt indicator

- Keep the cabinet upright during transportation and handling, including both before and after unpacking. The tilt angle shall not exceed 15° ($\alpha \leq 15^\circ$).

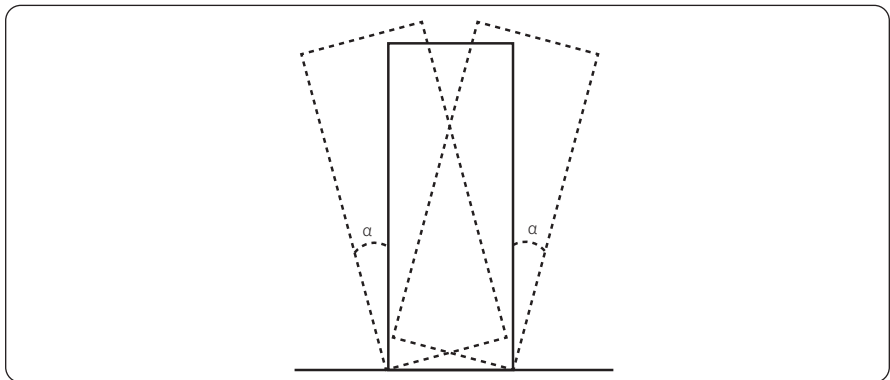

Figure 3-4 Tilt angle requirement during transportation

WARNING!

- If the tilt angle exceeds 15° ($\alpha > 15^\circ$) during transportation and handling, including both before and after unpacking, the cabinet must be placed upright and allowed to stand for 4–24 hours before installation. Failure to do so may result in abnormal compressor operation or damage due to lubricating oil or refrigerant backflow.

- For specific fork holes after unpacking, please refer to “6.1 Cabinet Handling”.
- The equipment can only be transported by forklift before unpacking.

3.1.2 Hoisting

- A hoist operator with good operational skills and safety awareness, who must be trained and certified, shall be operated according to the local laws and regulations.
- After unpacking, the following requirements must be met when working with cranes and lifting ropes: crane hoisting capacity ≥ 5 t, hoisting operating radius ≥ 2 m.
- Before hoisting, please check:
 - » Lifting tools are complete, tested and fully secured.
 - » The device door is closed and locked to avoid accidental opening.
 - » The lifting rope's quality must meet standards, and it shall be fully secured, to avoid falling and fraying.
- Do not hoist outdoors in rain, snow, wind and other bad weather.
- It is recommended to hoist devices in sequence and to ensure that the hoist moves in the same direction.

3.2 Storage Requirements

3.2.1 Cabinet Storage

- For long-term storage, do not remove the original packaging and check the packaging regularly.
- Please strictly comply with the storage requirements of the warning signs and other information on the packaging to avoid device damage.
- Storage temperature: -20°C to $+60^{\circ}\text{C}$.
- Relative humidity for device storage: 5%–95%.

NOTICE!

- Since the batteries have been installed in the cabinet in the factory, the storage requirements for the battery must also be abided by when storing the cabinet.

3.2.2 Battery Storage

 **DANGER!**

- The battery must be stored indoors, which the environment should meet the following requirements: 1. Avoiding direct sunlight and keeping out of rain; 2. Dry and well-ventilated; 3. Keeping away from heat and fire sources; 4. Keeping away from radiation; 5. Keeping away from chemicals; 6. Keeping away from dust and metal conductive dust; 7. Being equipped with fire facilities.
- Batteries must be stored in accordance with the requirements of the warning signs and other information on the packaging.
- Do not store with any other electronic equipment, chemicals, or other items that may cause interference or danger.
- Please pay attention to the height when stacking batteries to avoid deforming or damaging the battery at the bottom.

NOTICE!

- Do not store the batteries for a long time. If long periods of storage are unavoidable, please recharge it periodically to avoid battery damage. For details, see "[11.3.3 Maintenance of Battery Pack](#)".

- Regarding with the storage information, see the following table:

Table 3-1 Storage information

Storage temperature range	Recharge frequency
50°C to 60°C	Every 3 months
30°C to 50°C	Every 6 months
-20°C to 30°C	Every 12 months

- Relative humidity for device storage: 5%–95%.
- If the battery has been stored for more than 1 year, it must be checked and tested by professionals before use.

4 Preparation Before Installation

4.1 Installation Site Selection

The installation site is critical to the safety, service life, and performance of the device, and it should be convenient for electrical connections, operation, and maintenance. Therefore, the installation site should be selected according to the *NFPA 855 Standard for the Installation of Stationary Energy Storage Systems* and the local laws and regulations.

The installation site shall meet the following requirements:

- **Laws, regulations and industry standards:** The selection of installation sites must strictly comply with local laws, regulations, and related industry standards.
- **Fire safety:** Fire extinguishers must be configured at the installation site according to the local fire codes, and a port for the water fire extinguishing system shall be reserved.
- **Installation area:** It is recommended to install the cabinet outdoors. If local regulations permit indoor installation, please ensure there is sufficient space for ventilation, heat dissipation, and maintenance.
- **Safety spacing:**
 - » The installation distance between the device and residential areas, population centers, or production buildings should meet the requirements of the local fire codes and standards.
 - » If the safety spacing cannot be met, a firewall that meets the requirements of the local fire codes must be built between the device and adjacent buildings. During the planning phase, it is crucial to consider the space for transportation, installation and maintenance of the device.
- **Flood and waterlogging prevention:**
 - » Avoid low-lying and flood-prone areas. The installation site that the device is to be located must be at least 250 mm higher than the highest water level in history.
 - » Since winds and wind-driven waves from rivers, lakes, and seas can affect the device, the foundation must be built at least 0.6 m higher than the maximum wave height in history.
 - » If a large amount of water flows in or through the energy storage power station, drainage facilities should be set up.
 - » If the installation site is prone to water accumulation, take waterproof measures, including but not limited to installing water baffles, configuring a drainage system, or raising the height of the foundation to prevent device damage.

- **Avoid liquid intrusion:** The installation area should be far away from the area where liquid is likely to be generated or leaked to avoid device failure.
- **Good transportation:** Good transportation for the installation site.
- **Reserve space:** During the planning phase, please consider the space for capacity expansion or connection in parallel in the future.
- **Avoiding bad soil:** Do not install devices on the undesirable soil that are prone to deformation and settlement.
- **Keeping away from salt-damaged and polluted areas:** Keep the cabinet away from coastlines and pollutants. If such conditions are unavoidable, please contact SolaX for advice before installation.

NOTICE!

- If the cabinet is installed in polluted areas, please clean the cabinet exterior regularly every 1 to 3 months, or perform cleaning more frequently in easily polluted areas.
- Do not use acidic or alkaline cleaning agents, and make sure to rinse the cabinet thoroughly with clean water after cleaning.

- **Additional fence:** For security reasons, the installation area should be surrounded by locking fences or walls accessible to qualified persons only.
- **Installation environment requirements:**
 - » Temperature: -30 °C to +55 °C.
 - » Relative humidity: 0–100% RH.
 - » Altitude: Below 3000 meters.
 - » Good ventilation.
 - » Keep away from sandy and dusty environments.
 - » Keep away from high temperature environment such as heat source and fire source, etc.
 - » Keep away from flammable and explosive materials and areas with dust.
 - » Keep away from corrosive substances.
 - » Keep away from strong electromagnetic fields and antenna.
 - » Keep away from strong vibration and noise sources.
 - » Keep away from areas with radiation.
 - » Keep away from areas with metal conductive and magnetic dust.
 - » Keep away from areas that produce or have toxic and harmful gases.
 - » Keep away from environments that are prone to microbial growth.

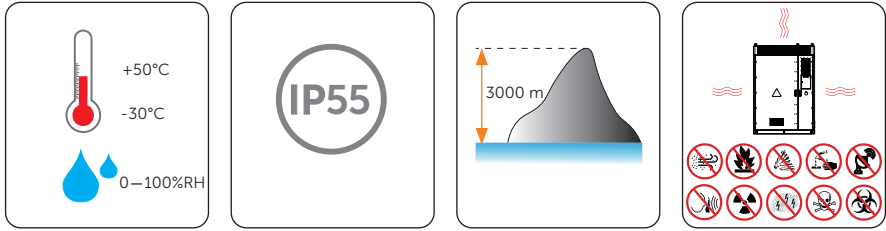

Figure 4-1 Installation environment requirements

4.1.1 Installation Foundation Requirements

The requirements for foundation are shown as follows:

- Type of foundation material:
 - » Non-combustible materials such as solid bricks or concrete.
 - » Steel.
- The bottom of the foundation pit must be strengthened and filled. The surface of the foundation shall be solid, flat and level (horizontal error $\leq 3\text{mm}$, tilt angle $\leq 5^\circ$). Sunken or tilted foundation is not acceptable.
- The foundation's bearing capacity shall exceed 5 t. Otherwise, a retest is required.

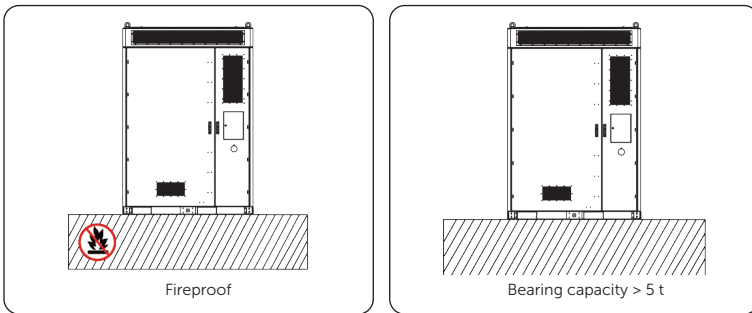

Figure 4-2 Foundation requirement

- A qualified drainage facility, of which the drainage capacity meets the requirements of the heaviest rain records in local history, shall be established according to the local geological conditions and municipal drainage standards.
- Reserve a trench or cable entry hole during the design phase.
- Avoid cables buried underground when constructing the foundation.
- The foundation drawing is only for reference. Operators shall recheck and revise it according to the environment, geological conditions, seismic requirements, etc. of the installation site.

Angle supports at the front and rear side

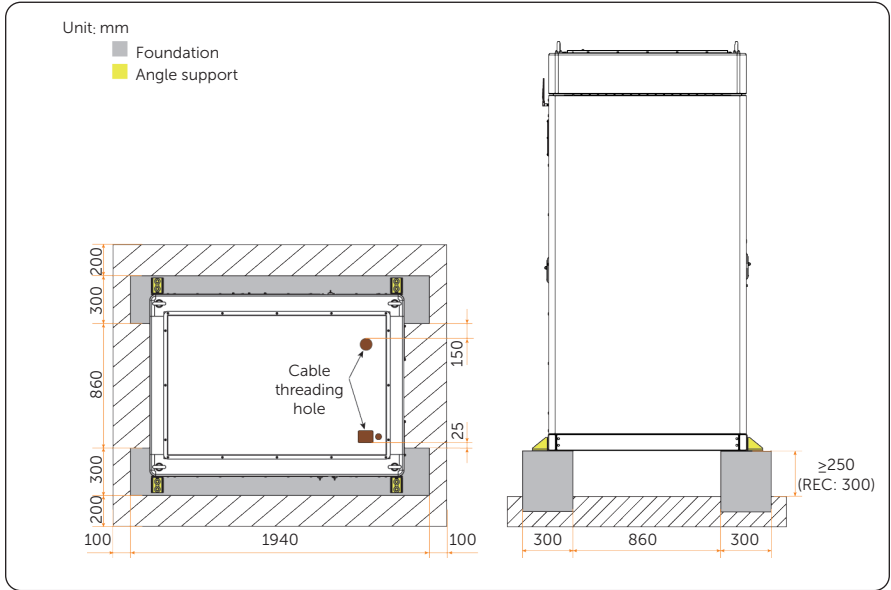

Figure 4-3 Foundation requirements for angle supports at front and rear sides

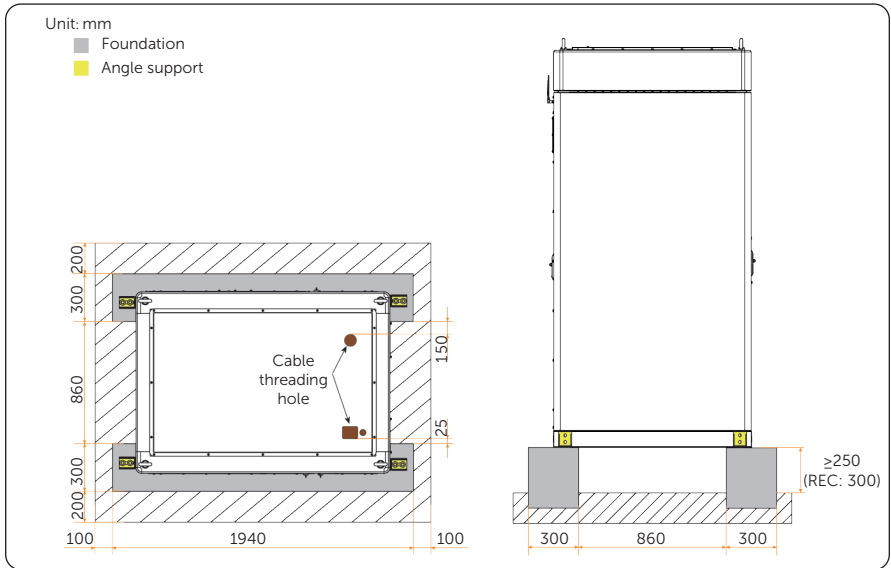

Figure 4-4 Foundation requirements for angle supports at left and right sides

Steel foundation

If you want the foundation to be made of steel, the foundation must meet the following requirements:

- Bearing capacity: > 5 t;
- Corrosion resistance: It is recommended to be subjected to a 720 hours salt spray test;
- Dimension and others: See the following figures.

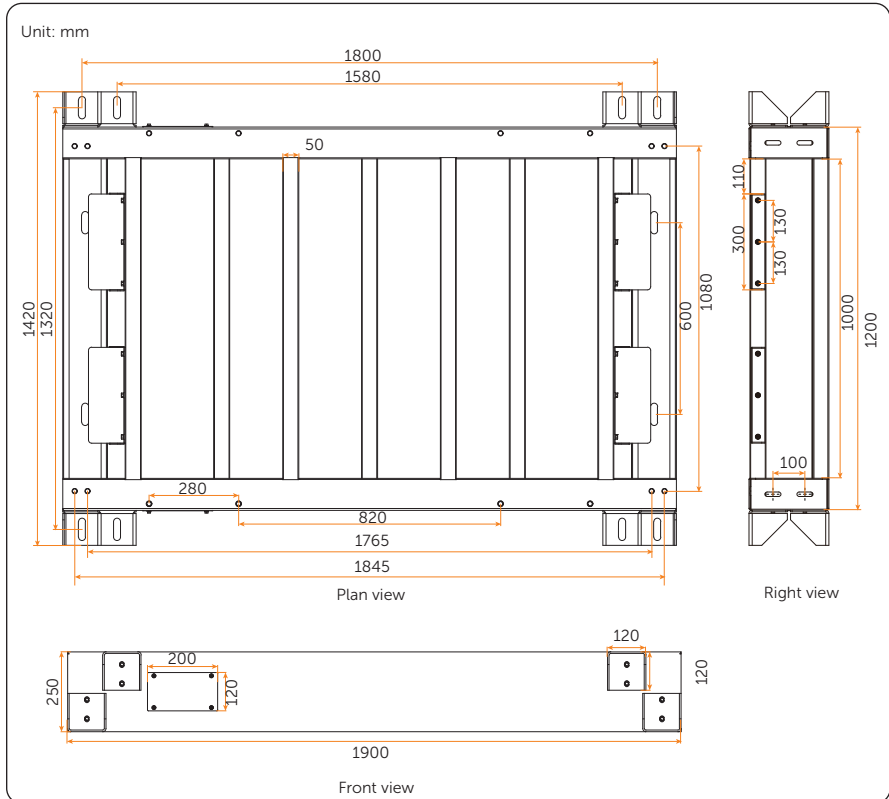

Figure 4-5 Dimension of steel foundation

Preparation Before Installation

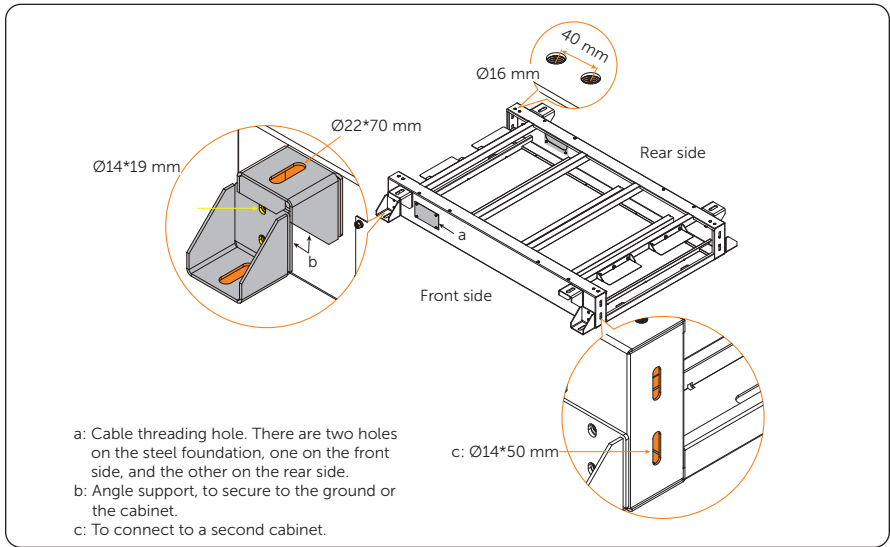

Figure 4-6 Detail description of steel foundation

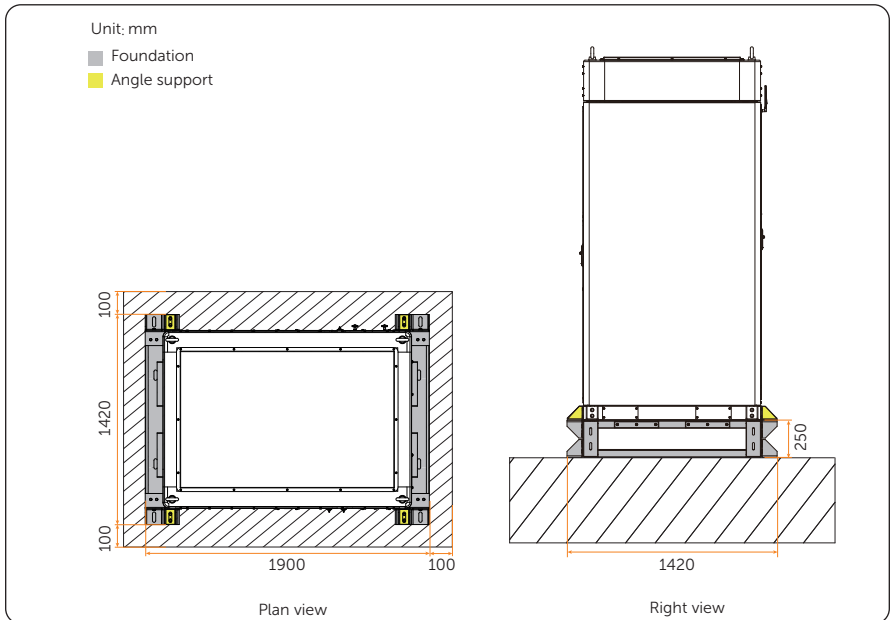

Figure 4-7 Angle supports at front and rear sides

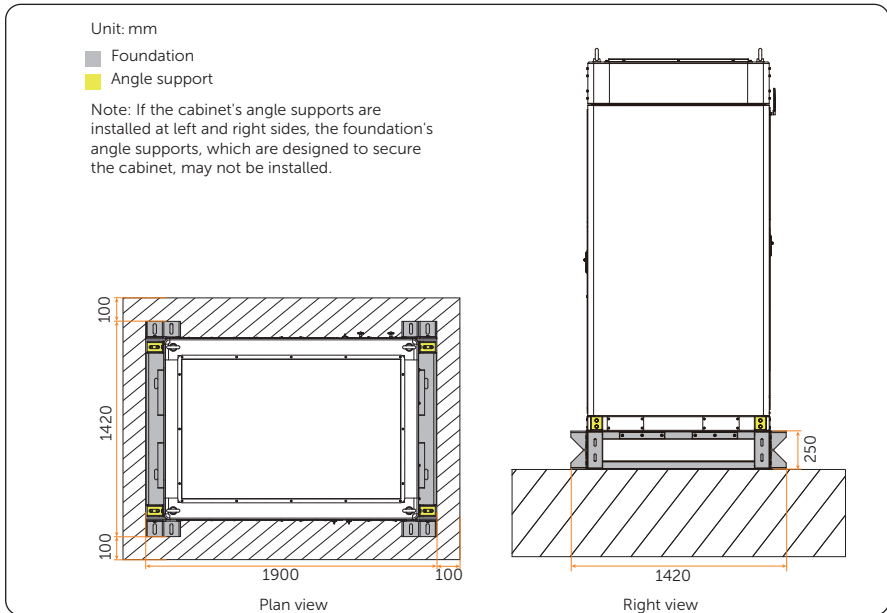

Figure 4-8 Angle supports at left and right sides

NOTICE!

After completing construction of the steel foundation, please strictly comply with the following steps:

- a. Install the bottom angle support first to secure the foundation to the ground;
- b. Install the top angle support (if any);
- c. Finally, install the cabinet onto the steel foundation.

After the steel foundation is finished, the installation procedure for cabinet can be referred to "6 Mechanical Installation".

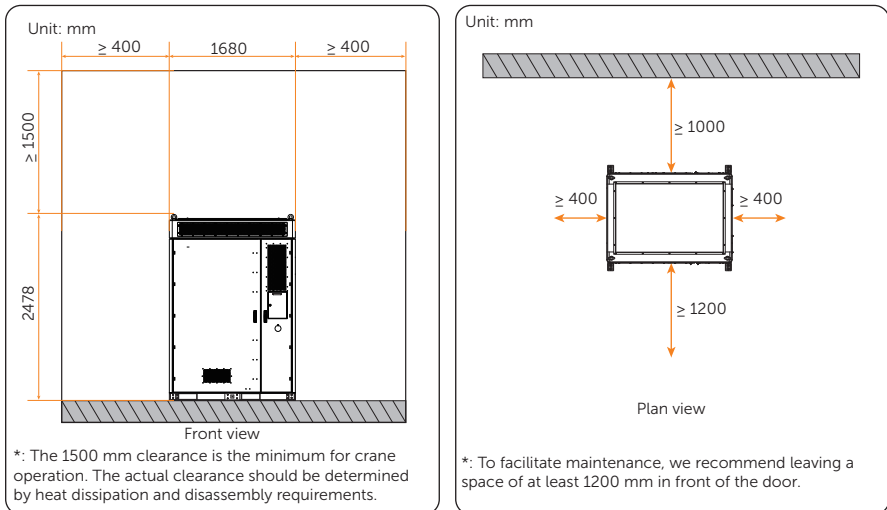

Figure 4-9 Final installation diagram

4.1.2 Clearance Requirements

Single cabinet

For a single cabinet, reserve a space of at least 400 mm at the left and right side, at least 1500 mm on the top for crane operation, at least 1000 mm in the rear, and at least 1200 mm for ease of maintenance in the front.



Multiple cabinets

When cabinets are placed in row, each two cabinets in the same row can be placed close to each other.

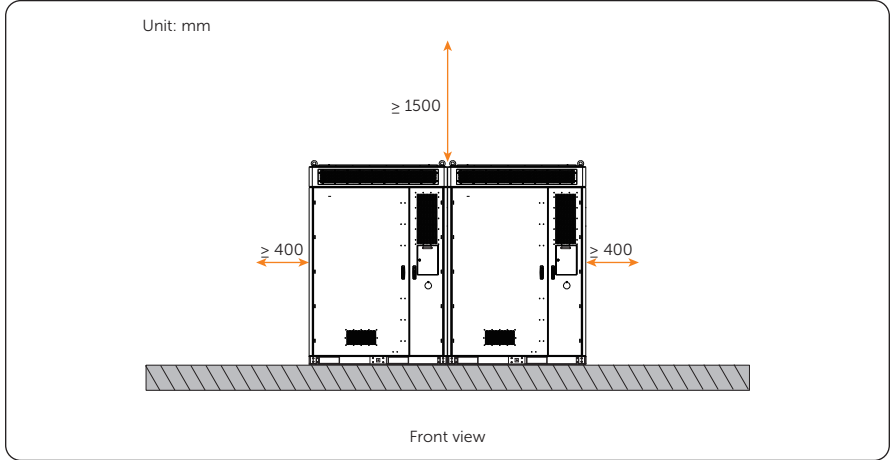

Figure 4-11 Multiple cabinets

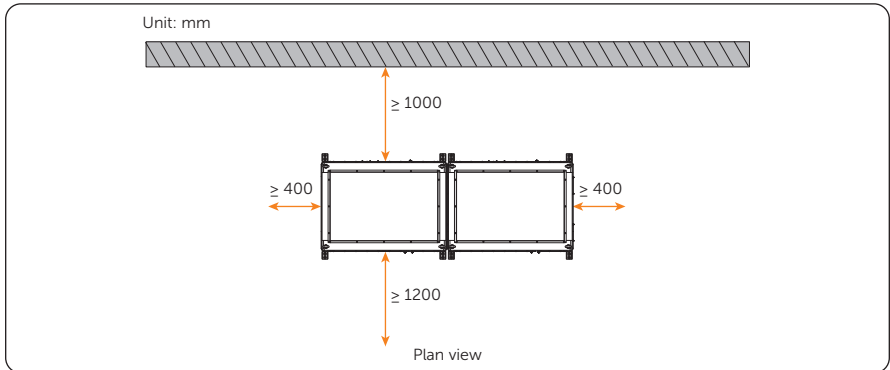
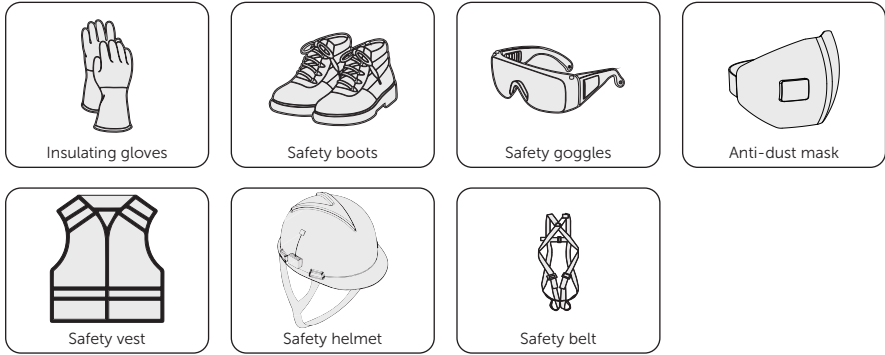

Figure 4-12 Multiple cabinets

4.2 Tool Requirements

The following tools are recommended; other appropriate tools may be used as required. Ensure all tools comply with local safety regulations.

 <p>Hammer drill (Ø18 mm)</p>	 <p>Multimeter (≥ 1500 V dc)</p>	 <p>Measuring tape</p>	 <p>Utility knife</p>
 <p>Marker</p>	 <p>Cross screwdriver</p>	 <p>Flat-head screwdriver</p>	 <p>Wire cutter</p>
 <p>Wire stripper</p>	 <p>Crimping tool for RJ45</p>	 <p>Hydraulic wire crimper</p>	 <p>Rubber mallet</p>
 <p>Torque wrench (M4-M12)</p>	 <p>Torque screwdriver (Phillips head: M4)</p>	 <p>Heat gun</p>	 <p>Heat shrink tubing (Ø30-60 mm)</p>
 <p>Diagonal pliers</p>	 <p>Vacuum cleaner</p>	 <p>Cable tie</p>	 <p>Insulated ladder</p>
 <p>Crane</p>	 <p>Steel wire rope (Length > 2000 mm*4)</p>	 <p>Electric forklift</p>	 <p>Metal rod ≤ Ø40 mm</p>



4.3 Additionally Required Materials

NOTICE!

- Select either grounding plate, or PE wire and ring terminal to ground the cabinet.
- If you use wire rather than grounding plate for cabinet grounding, prepare the PE wire and ring terminal of corresponding specification.

Table 4-2 Additionally required wires

No.	Required Material	Type	Conductor Cross-section
1	Grounding plate 	Galvanized iron plate	Width: 40 mm Depth: 4 mm
2	Grid cable 	Five-core copper cable (L1, L2, L3, N wires: 50 mm ² PE wire: 35 mm ²)	Conductor cross-section: 50 mm ² *4 + 35 mm ² *1
3	Additional PE wire 	Conventional yellow and green wire	Conductor cross-section: 50 mm ²
4	Ethernet cable 	CAT 5E	/

Preparation Before Installation

No.	Required Material	Type
1	RJ45 	/

5 Unpacking and Inspection

5.1 Unpacking

- The equipment undergoes 100% testing and inspection before shipping from the manufacturing facility. However, transport damage may still occur. Before unpacking the rechargeable battery, please verify that the model and outer packing materials for damage, such as holes and cracks.
- Due to the cabinet height exceeding 2 m, please take necessary precautions for working at heights when removing the outer packaging.

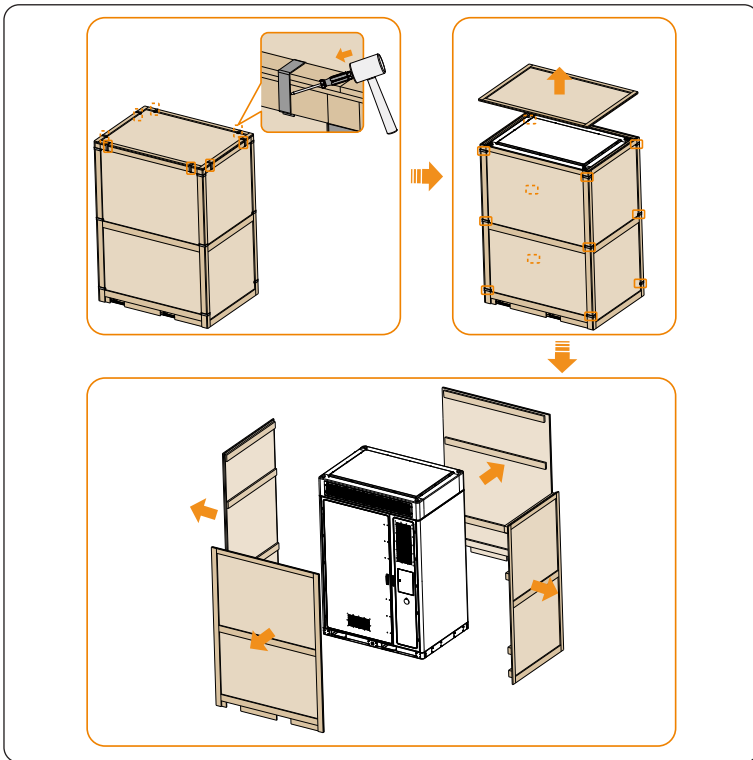
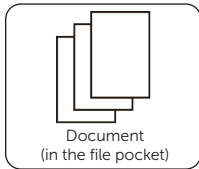
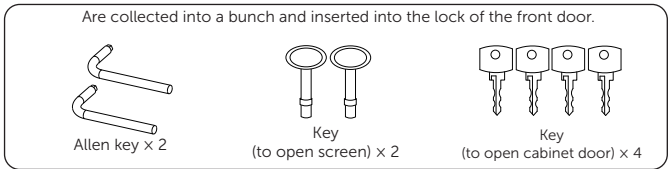
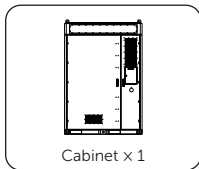

Figure 5-1 Unpacking

- When unpacking, please handle all packaging materials properly for future storage or relocation of this equipment.
- After unpacking, please check if the equipment is intact and if all accessories are complete. If there is any damage or missing accessories, please contact your dealer immediately for assistance.

5.2 Packing List

Cabinet and accessories stored inside it



Accessory kit

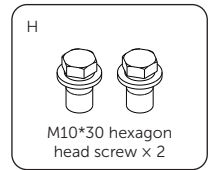
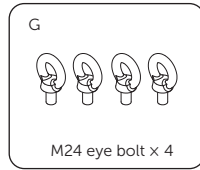
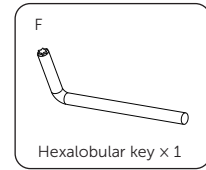
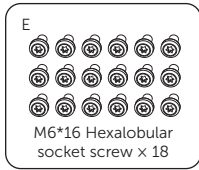
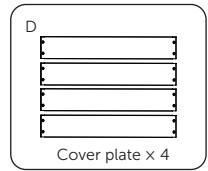
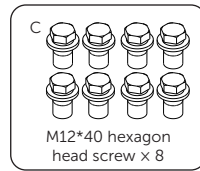
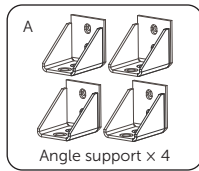

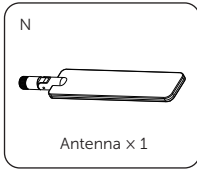
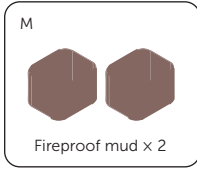
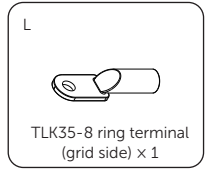
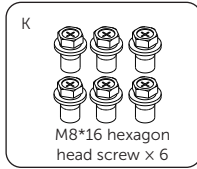
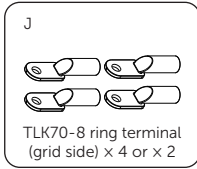
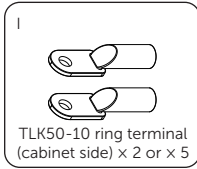

Optional accessory

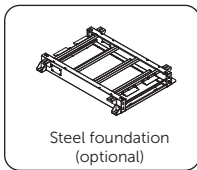

Table 5-1 Packing list

Item No.	Items	Quantity (PCS)
/	Cabinet	1
/	Allen key	2
/	Key (to open screen)	2
/	Key (to open cabinet door)	4
/	Document	/
A	Angle support	4
B	M12 Expansion bolt	10
C	M12*40 hexagon head screw	8
D	Cover plate	4
E	M6*16 Hexalobular socket screw	18
F	Hexalobular key	1
G	M24 eye bolt	4
H	M10*30 hexagon head screw	2

Unpacking and Inspection

Item No.	Items	Quantity (PCS)
I	TLK50-10 ring terminal	2 for the Type A cabinet and 5 for the Type B cabinet
J	TLK70-8 ring terminal	4 for the Type A cabinet and 2 for the Type B cabinet
K	M8*16 hexagon head screw	6
L	TLK35-8 ring terminal (grid side)	1
M	Fireproof mud	2
N	Antenna	1
/	Steel foundation	Optional

NOTICE!

- Refer to the actual delivery for the optional accessories.
- The steel foundation are sold separately.

6 Mechanical Installation

After determining the installation site, please take out the required underground cables.

WARNING!

- Avoid installing, operating and maintaining the device or cables outdoors under severe weather conditions such as lightning, rain or snow.
- The device must be installed by professionals in accordance with local regulations and standards.
- Before drilling, please check and ensure that the area is free of pipes, light switches, sockets, and wires, and safe to drill into.
- Please wear PPE, and take steps to cover the device to prevent debris from entering it while drilling holes.
- After drilling, clean up the site in time.

NOTICE!

- Before installation, please refer to "4.1.2 Clearance Requirements" for installation, ensuring sufficient space is reserved for the installation and heat dissipation of the entire equipment.

6.1 Cabinet Handling

NOTICE!

- There are two ways to move a cabinet: using a crane or a forklift. Please refer to "3.1 Transportation Requirements" for related handling precautions.

6.1.1 Crane Hoisting

NOTICE!

When hoisting:

- Temporary warning signs or fences should be set up in the hoisting area, and only the qualified persons can access it.
- Never stand and walk under or near the device being lifted or lowered.
- For safety reasons, avoid long-distance hoisting operations.
- Please be careful when hoisting and placing the device, and do not remove the ropes before it is seated on the foundation. Please make sure that the boom lift moves level and the cabinet's tilt angle is $\leq 5^\circ$ during hoisting.
- The angle in both the diagonal ropes shall be $\leq 60^\circ$.
- Do not lift the next one before the previous cabinet has been installed on the foundation.

Step 1: Remove the top bolts, install the eye bolts (part G) with the rod and tighten them securely.

NOTICE!

- Put the silicone gaskets in place before inserting the eye bolts.
- Ensure that the eye bolt's shoulder makes total contact with the silicone gasket.

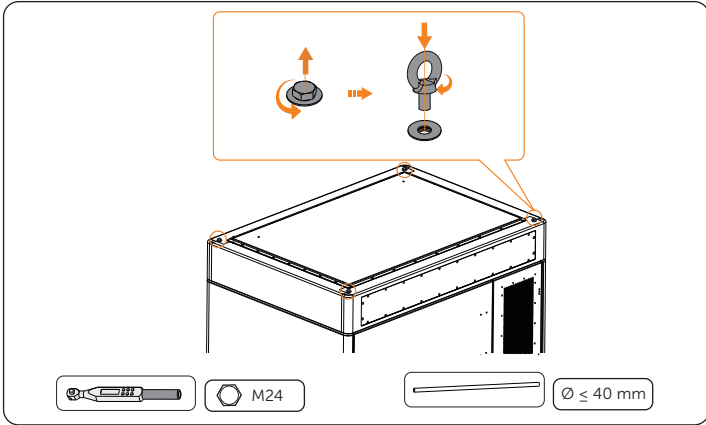

Figure 6-1 Installing eye bolts

Step 2: Attach the steel wire ropes to all hoisting points, keep the hoisting angle within the specified range, and make sure the ropes are evenly tensioned before hoisting.

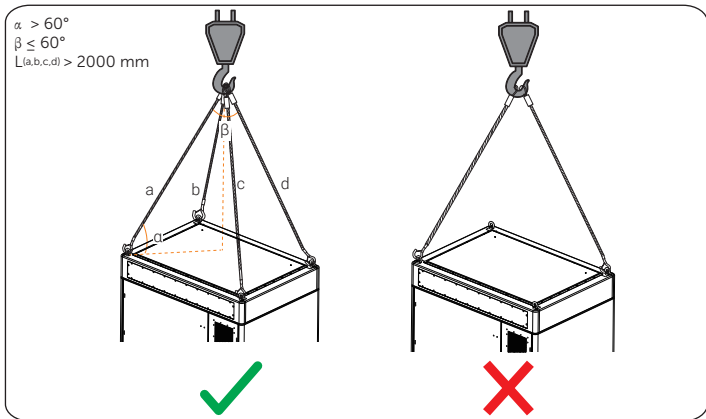

Figure 6-2 Attaching steel wire ropes

6.1.2 Fork Handling

NOTICE!

- Before relocating the cabinet through a forklift truck, make sure you have secured the cabinet properly without any risks of tipping over.

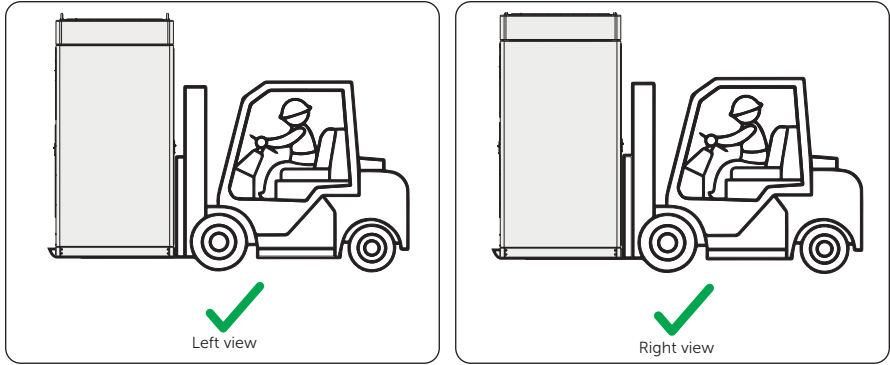

Figure 6-3 Right positions

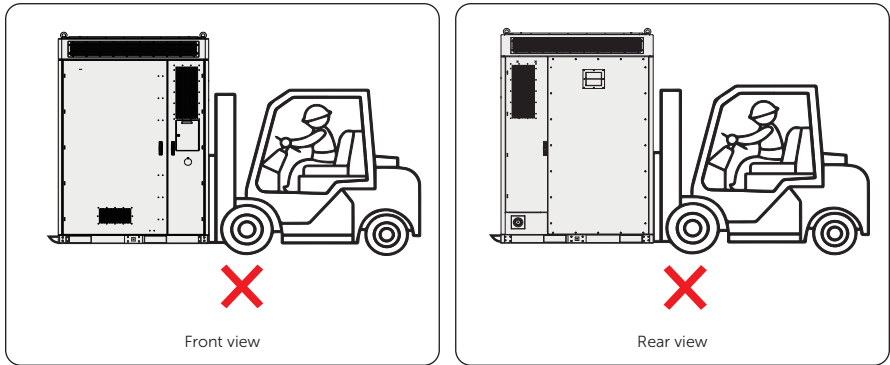

Figure 6-4 Wrong positions

NOTICE!

- After unloading the cabinet from the forklift truck, check if there is any paint peeling or chipping. If there is, follow the instructions on "[13.3 How to Repair the Cabinet](#)" to repair.

6.2 Cabinet Installation

You can install the angle supports at the front and-rear sides or at the left and-right sides of the cabinet to secure the cabinet. Since the installation procedure for the angle support is the same, take the angle support installed at the front and-rear sides, for instance.

Step 1: Attach the angle supports (part A) to the cabinet, insert M12 screws to secure the supports using a torque wrench, and draw a circle on the bottom of the angle support.

NOTICE!

- The distance between two holes should be: $40\text{ mm} \leq D < 50\text{ mm}$. There are totalling 4 angle supports for a cabinet.

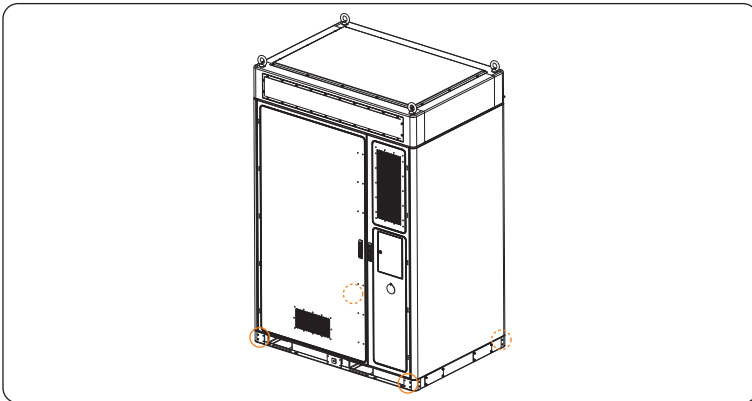

Figure 6-5 Installation position

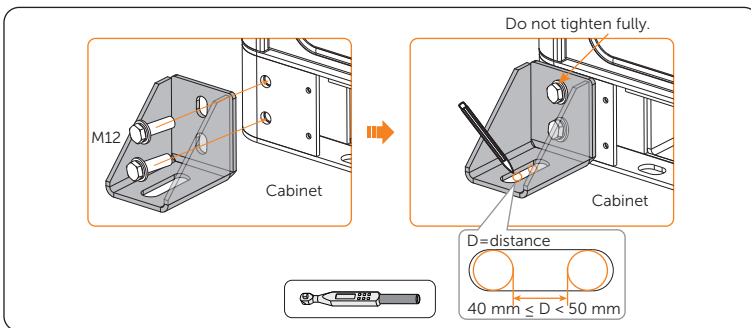

Figure 6-6 Marking hole position

Step 2: Mark the drilling positions, drill holes, and clean the site.

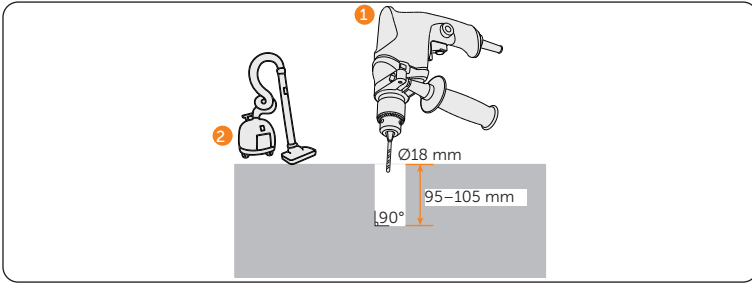

Figure 6-7 Drilling

Step 3: Reattach the angle supports to the cabinet, and insert M12 screws (Part C) and tighten them clockwise using a torque wrench.

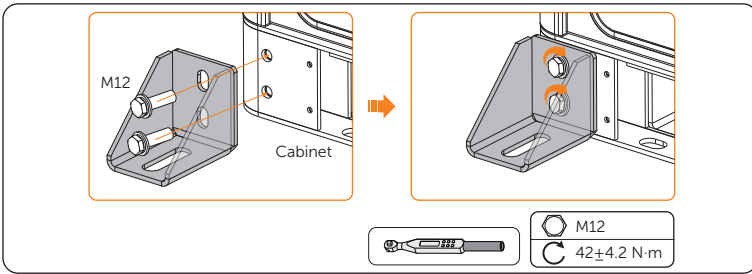

Figure 6-8 Tightening M12 screws

NOTICE!

- Reinstall the angle supports, ensuring that the screw holes on the angle support align with the screw holes on the cabinet and foundation.

Step 4: Use a rubber hammer to drive the expansion bolts (Part B) into the foundation screw holes, and then tighten them clockwise with a torque wrench.

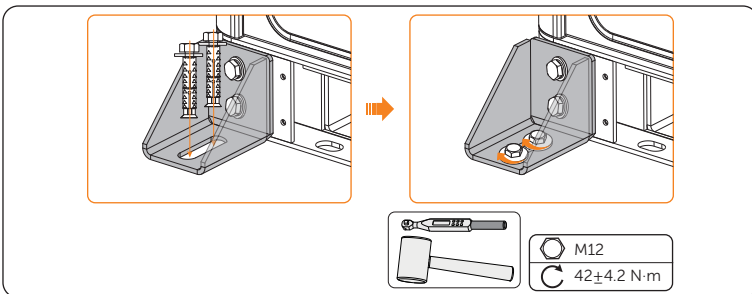

Figure 6-9 Tightening expansion bolts

Step 5: Remove the covers (part D) to seal the forklift hole and tighten the M6 hexalobular screws (part E) with the hexalobular key (part F).

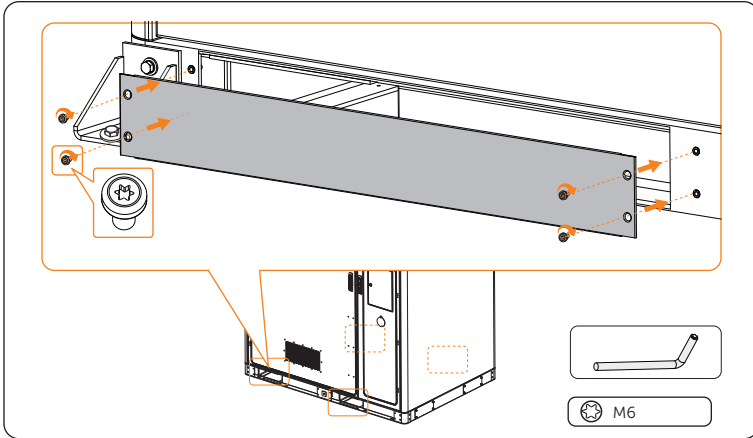

Figure 6-10 Fixed covers

NOTICE!

- The above-mentioned installation steps also apply to the angle supports, which are installed on both the left and right sides.

6.3 Removal of Detector and Sensor Protective Covers

Remove the protective covers from the smoke detector and temperature sensor before use.

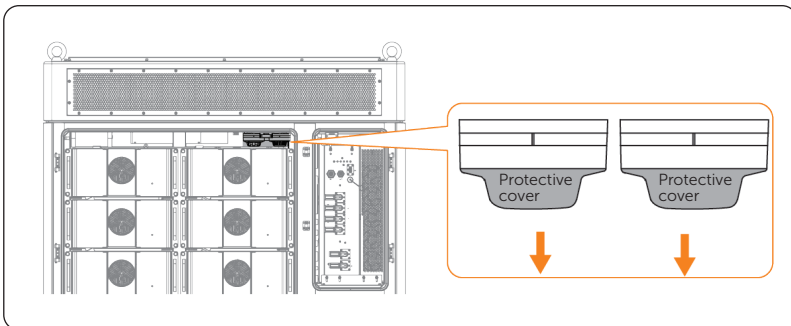

Figure 6-11 Removing the protective covers

7 Electrical Connection

The system features easy and convenient electrical connection. Most connections are already performed upon delivery, and you only need to connect the system to grid and ground for operation, or connect to more cabinets or other devices for varied functions.

Since the wiring is identical for both types, this section uses Type B as the reference. For product type identification, see "2.2.2 Product Type Identification".

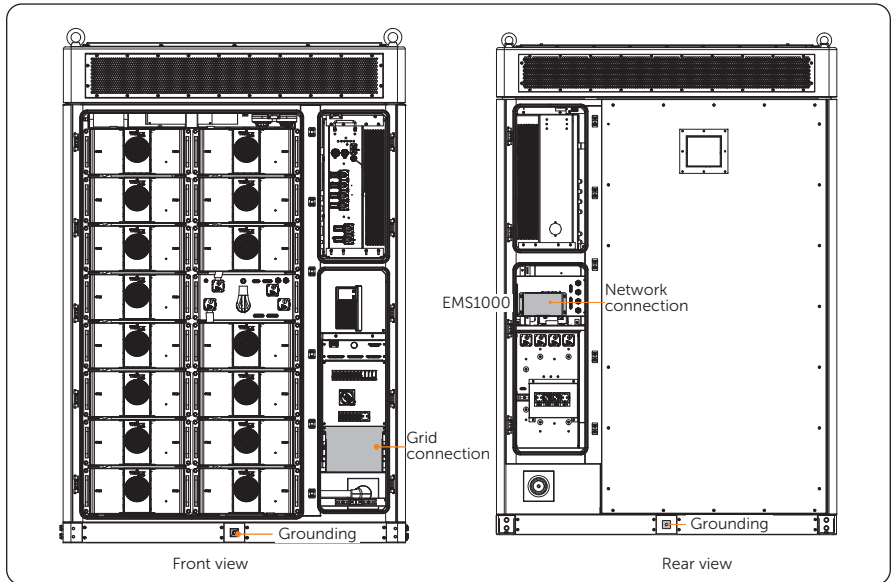

Figure 7-1 Position of the wired parts

7.1 Grounding Connection

You can ground the cabinet by the grounding plate or the PE wire.

NOTICE!

- The grounding plate or the PE wire is prepared by yourself. For details, please refer to "4.3 Additionally Required Materials".

Grounding plate connection

Step 1: Remove the M10 combination screw from the grounding terminal.

Step 2: Align the grounding plate to the grounding terminal, and then secure them using the M10 screw (Part H).

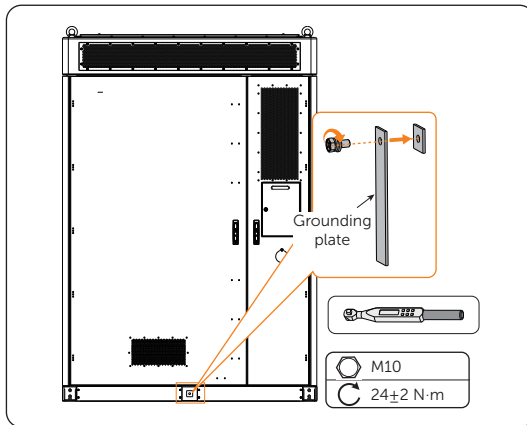

Figure 7-2 Securing grounding plate

PE wire connection

Step 1: Remove the M10 combination screw from the grounding terminal.

Step 2: Strip the outer jacket off the PE wire to an appropriate length.

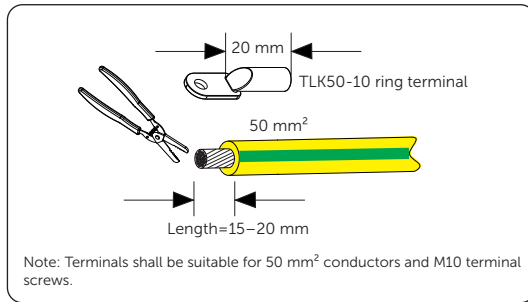

Figure 7-3 Stripping cable jacket

Step 3: Cut a section of heat-shrink tubing, thread it through the stripped cable, and then attach the ring terminal (Part I).

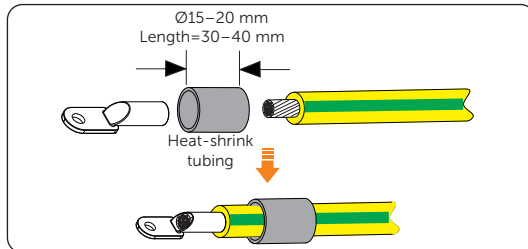

Figure 7-4 Cutting heat-shrink tubing

Step 4: Crimp the terminal, and heat the heat-shrink tubing after it wraps the end of terminal.

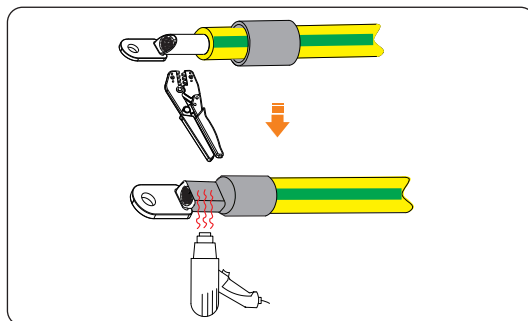

Figure 7-5 Crimping and heating

Step 5: Align the ring terminal of the PE wire to the grounding terminal, and then secure them using the M10 screw.

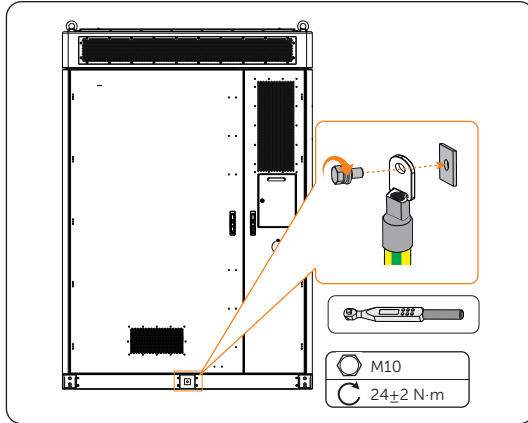

Figure 7-6 Securing PE wire

7.2 Grid Connection

NOTICE!

- Take out the underground electrical wiring which is buried beneath the ground.
- Regarding the terminal requirements, please refer to "13.2 Requirements for OT/DT Terminal".

Step 1: Make the grid cable.

NOTICE!

- We recommend conducting a health check for the grid cable before stripping it.
- Use controlled motion to strip the jacket and insulation layer to prevent damages on the wires.
- Make sure that the insulation layer has been stripped to a sufficient length so that the conductor is fully exposed without any damage or nicks. In addition, make sure that no extra insulation remains beyond the connector once it's crimped on.

- a. Strip the outer jacket and insulation layer off the grid cable to an appropriate length.

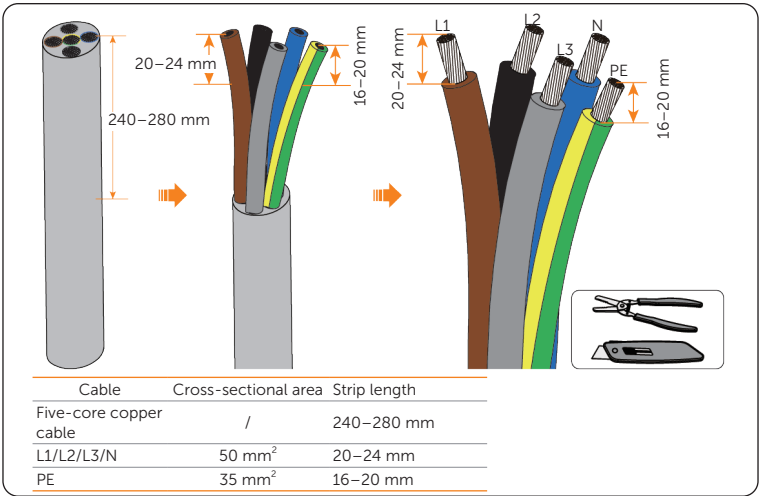

Figure 7-7 Stripping the cables

- b. Cut sections of the heat-shrink tubings, thread them through the stripped cables, and then attach the ring terminals.

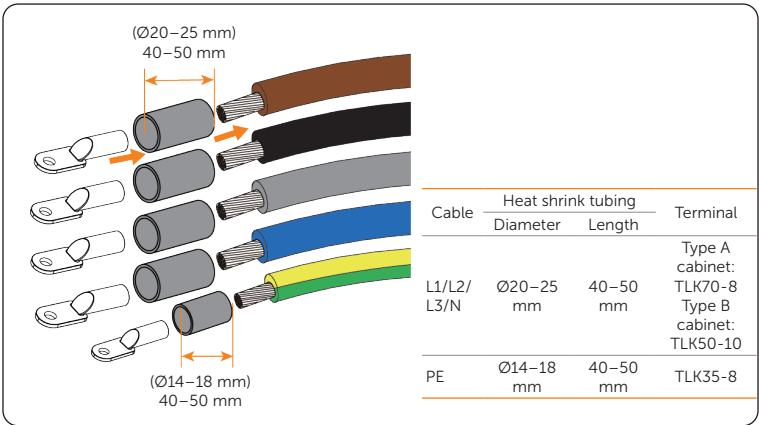

Figure 7-8 Attaching tubing and ring terminals

- c. Crimp the ring terminals, pull the heat-shrink tubings to the crimped area, and then heat them with a heat gun.

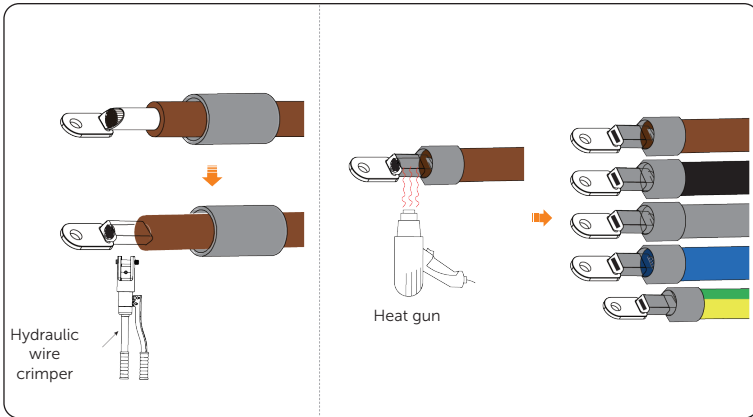

Figure 7-9 Crimping terminal

NOTICE!

- Do not damage the conductor insulation while crimping.
- Do not place the conductor insulation into the terminal.
- Move the heat gun back and forth slowly to distribute the heat evenly across the surface of heat shrink tubing.

Step 2: Use the keys to open the front doors before wiring.

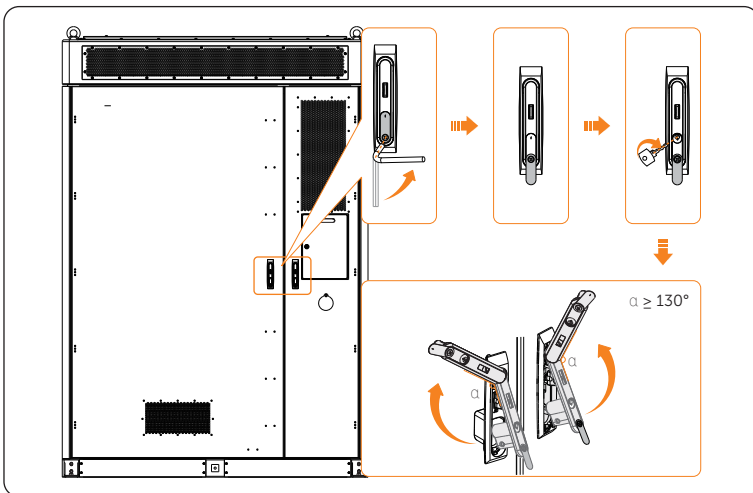

Figure 7-10 Opening front doors