

ALUMERO

EN

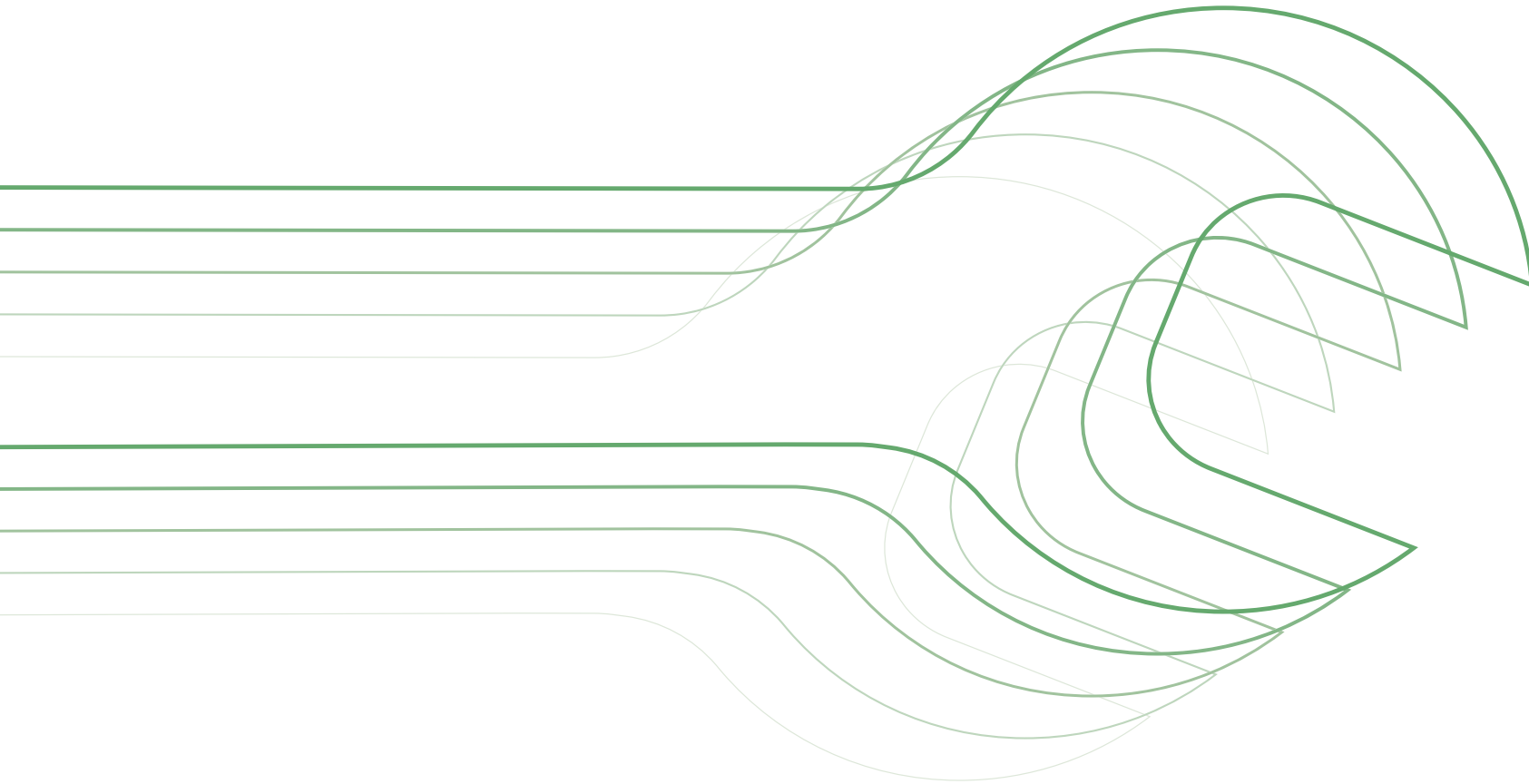

**SUSTAINABLE
SOLAR
SOLUTIONS**

easyLIGHT
South
ASSEMBLY MANUAL

Please read the safety instructions at the end of this manual before starting the installation. Make sure you are using the latest version of the assembly manual.

The layout and planning of the mounting system should be done using the **ALUMERO.PRO.TOOL** software. Refer to the required materials, positions, and arrangement of individual components as detailed in the project report provided by ALUMERO.PRO.TOOL or your ALUMERO sales representative. This data has been statically calculated and are essential for the safe and proper functioning of the system.

The installer of the photovoltaic system must ensure before installation begins that the roof substructure provided is designed for the additional loads.

This manual describes the assembly processes for the according ALUMERO system, attachment in open terrain, and the installation of modules.

This ALUMERO mounting system is designed exclusively for mounting PV modules. Any other use is considered inappropriate.

Installation must only be performed by qualified personnel. Roofing work in particular should be carried out by a roofing professional.

For further questions, use ALUMERO's professional and comprehensive consulting service.

TABLE OF CONTENTS

Technical Data	p. 3
Components	p. 4-8
Variants	p. 9-11
Installing modules	p. 12-19
Installing alpine supports	p. 20-21
Installing wind deflection	p. 22-24
Installing ballastage	p. 25-32
Installing roof anchors	p. 33-35
Potential equalisation Grounding	p. 36
Notes Legal notice	p. 37-40

TECHNICAL DATA

Application:	Foil-bitumen roofs as well as gravel and green roofs
Module dimensions:	950 - 1150 mm × 1500 - 2250 mm (width x length)
Module tilt angle:	5 - 15° (south-facing)
Surface clearance:	Approx. 60 mm
Roof inclination:	Up to 5° depending on roof conditions without roof anchor possible, over 5° only with roof anchor
Wind load:	Suction load up to 2.4 kN/m ²
Snow load:	Standard up to 2.4 kN/m ² , Alpine version up to 4.4 kN/m ²
Proof of stability:	Software-supported on the basis of wind tunnel analyses
Roof properties:	The static load-bearing capacity of the roof structure and the building support structure as well as sufficient compressive strength of the thermal insulation must be ensured on site.
Material underconstruction:	Aluminium EN AW 6060; sheet metal made of steel with aluminium-zinc coating; small parts made of stainless steel A2-70 stainless steel; building protection mat made of polyester fleece.

REQUIRED TOOLS



Cordless screwdriver
with bit inserts:
Hexagon SW 6

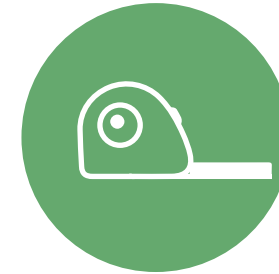

Measuring tape



Torque wrench

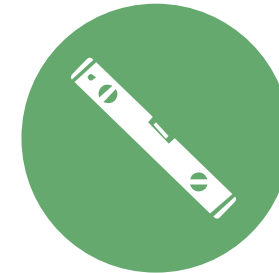

Spirit level



Chalk line

COMPONENTS

EASYLIGHT S5

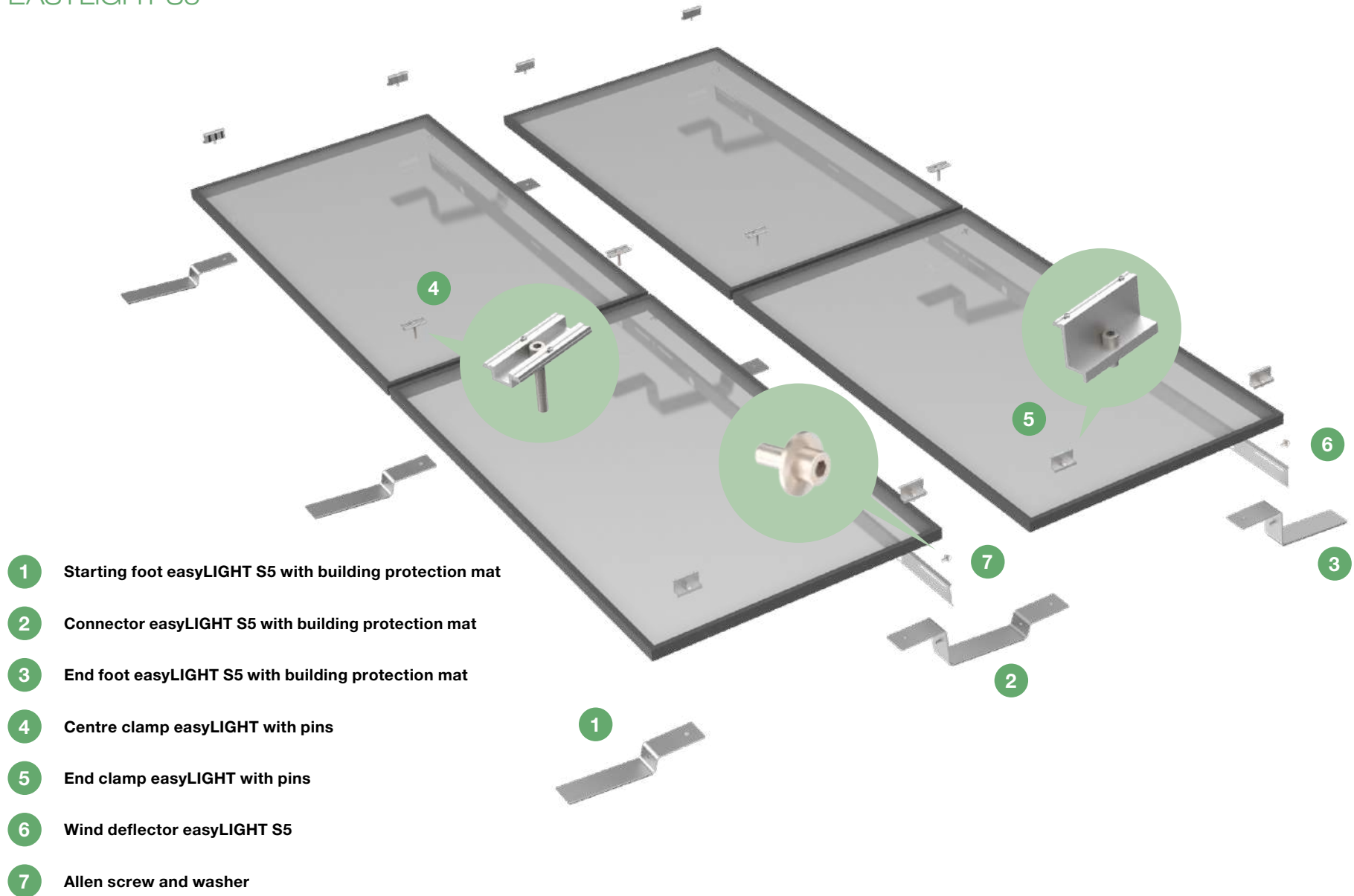

COMPONENTS

EASYLIGHT S10

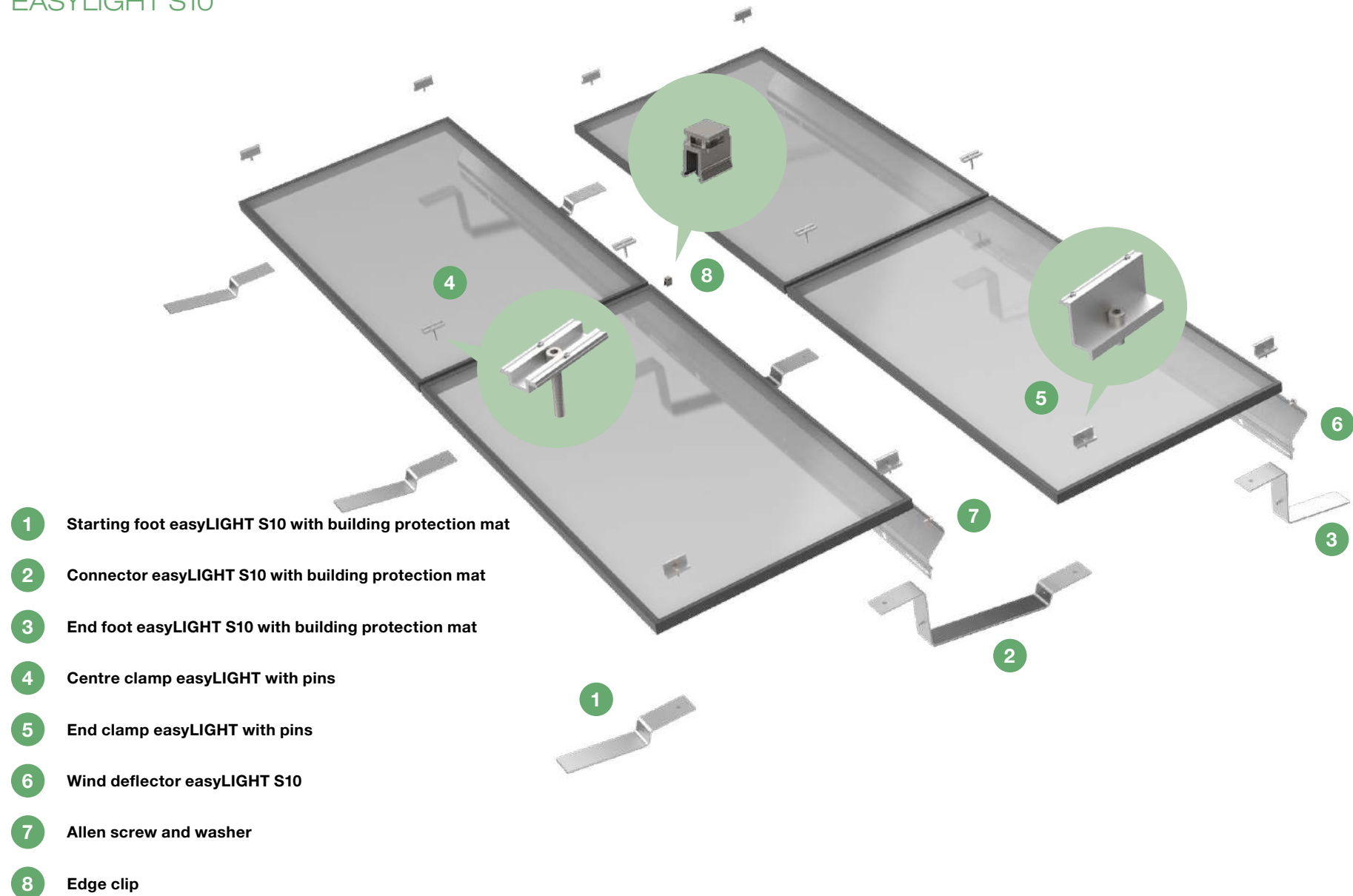

COMPONENTS

EASYLIGHT S15

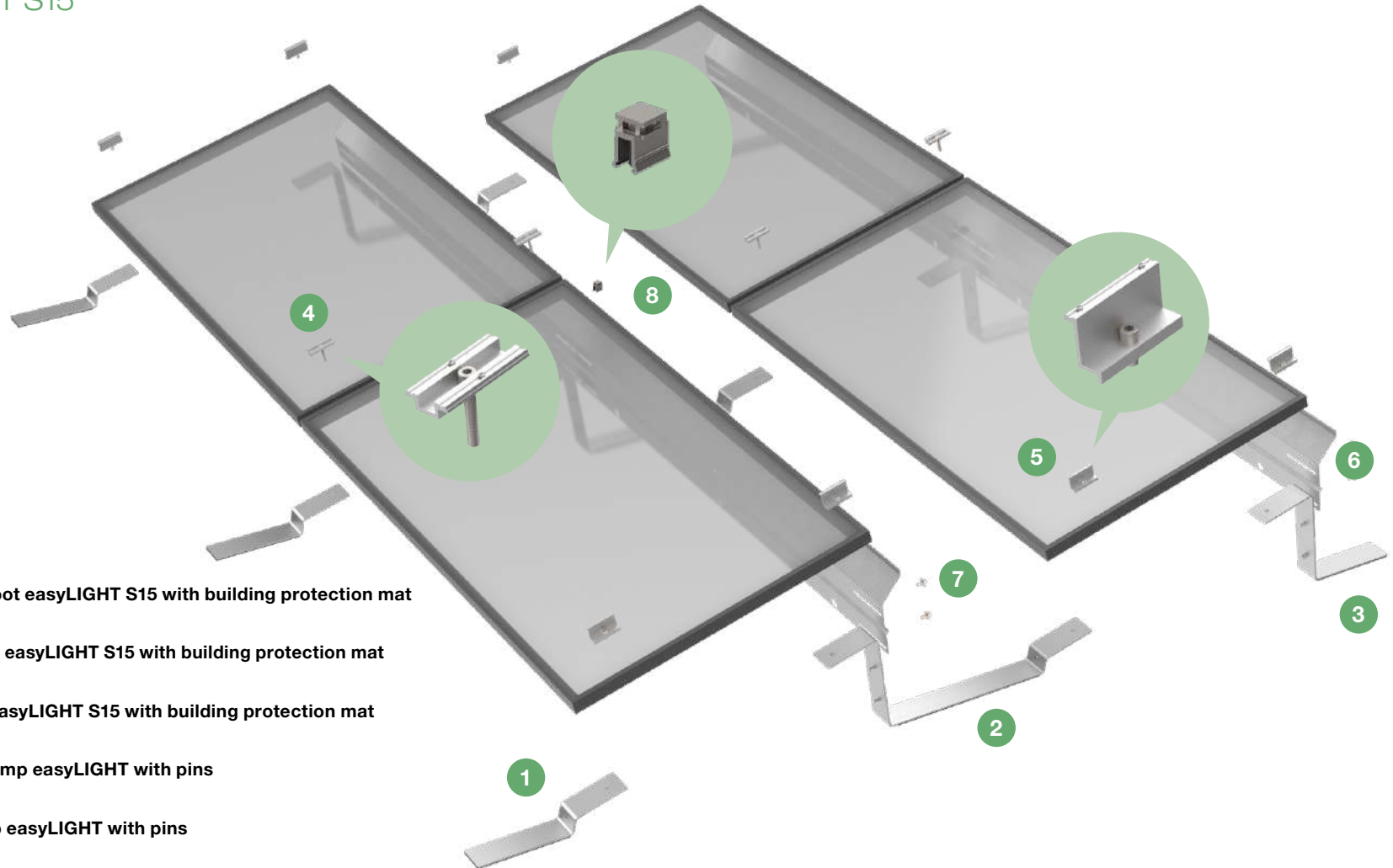

- 1 Starting foot easyLIGHT S15 with building protection mat
- 2 Connector easyLIGHT S15 with building protection mat
- 3 End foot easyLIGHT S15 with building protection mat
- 4 Centre clamp easyLIGHT with pins
- 5 End clamp easyLIGHT with pins
- 6 Wind deflector easyLIGHT S15
- 7 Allen screw and washer
- 8 Edge clip

COMPONENTS

BALLASTAGE

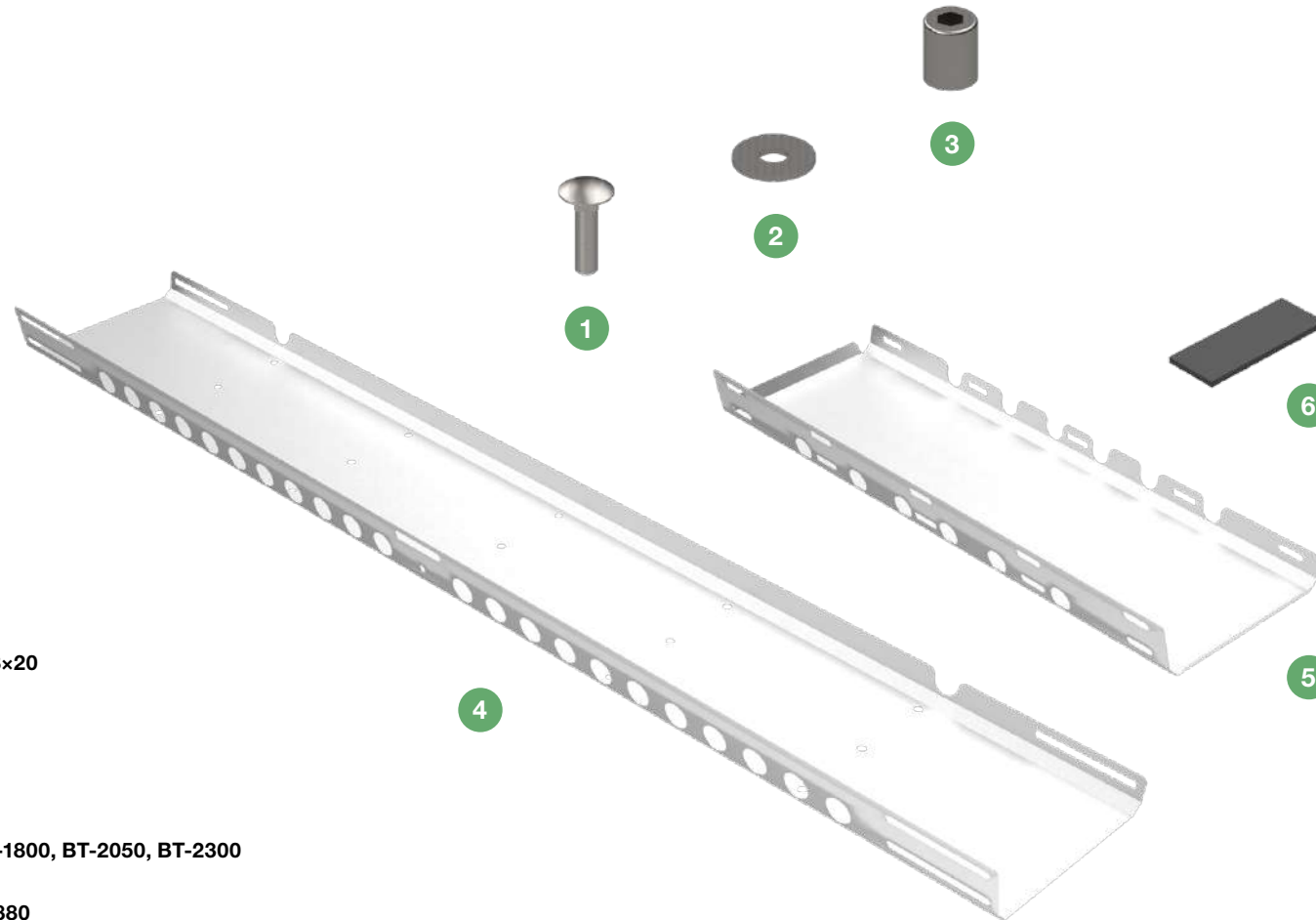

- 1 Gate hinge screw, M8x20
- 2 Washer
- 3 Allen nut, M8 SW6
- 4 Long ballast tray, BT-1800, BT-2050, BT-2300
- 5 Short ballast tra, BT-880
- 6 Building protection mat, PES

COMPONENTS

ALPINE SUPPORTS

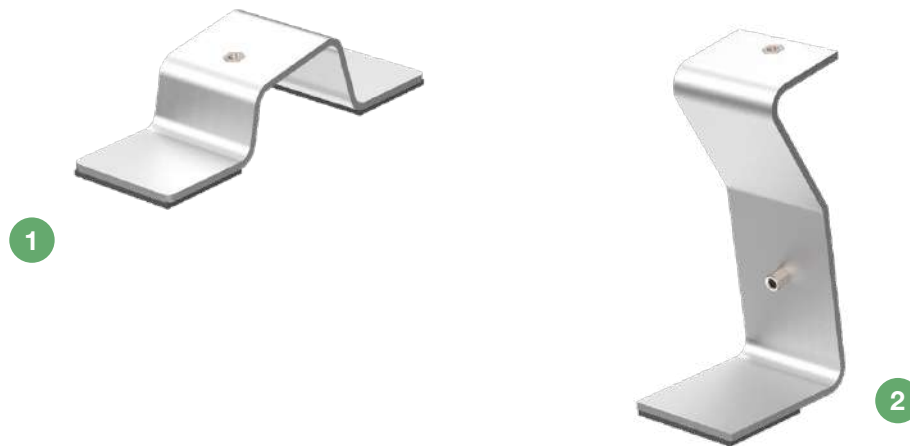

1 Front alpine support (easyLIGHT S5 / S10 / S15) with building protection mat

2 Rear alpine support (easyLIGHT S5 / S10 / S15) with building protection mat

VARIANTS

FLAT ROOF EASYLIGHT S5

178 mm spacing 30° internal shading angle



FLAT ROOF EASYLIGHT S5

335 mm spacing 15° internal shading angle



VARIANTS

FLAT ROOF EASYLIGHT S10

380 mm spacing 25° internal shading angle



FLAT ROOF EASYLIGHT S10

527 mm spacing 18° internal shading angle



VARIANTS

FLAT ROOF EASYLIGHT S15

571 mm spacing 25° internal shading angle



FLAT ROOF EASYLIGHT S15

790 mm spacing 18° internal shading angle



INSTALLATION

INFORMATION ON MOUNTING ON GRAVEL ROOFS

The planning documents define whether the system is to be installed directly on the directly on the waterproofing or the protective fleece (coefficient of friction 1.5) or placed freely on the gravel (coefficient of friction 0.3).

Install the system on waterproofing or protective fleece

Height of gravel fill: 30 - 60 mm

As excessive point loads can cause damage to the roof waterproofing, do not install the system on a gravel layer of up to 60 mm. on the gravel.

- + Carefully remove the gravel in the area of the module field.
- + Set up the system directly on the waterproofing or on the protective fleece.

Use the gravel for ballasting after assembly according to the ALUMERO.PRO.TOOL report for ballasting.

Set up the system on the gravel

Gravel fill 60 - 100 mm and protective fleece (min. 300 g/m²) is present or gravel fill is 100 mm or higher.

- + Place the system on the gravel.

INSTALLATION

PRE-ASSEMBLE CLAMPS

+ Attach the end or centre clamps to the start legs, connectors and end legs as required.

End clamps

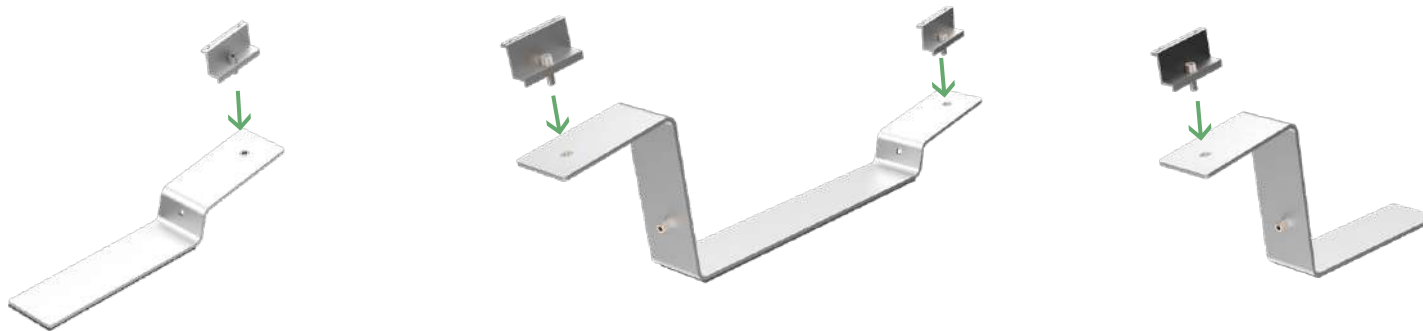

Centre clamps

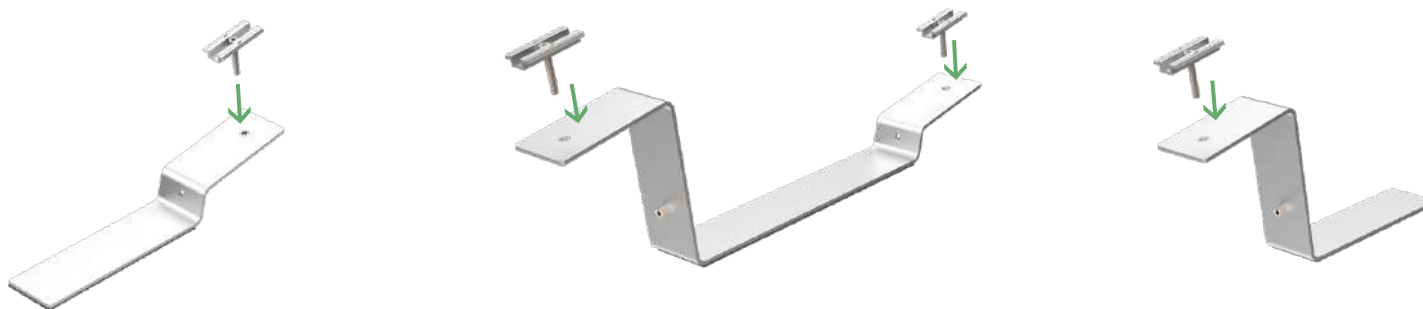

INSTALLATION

MEASURE AREA, PLACE COMPONENTS

- + Take the dimensions of the module field from the planning documents.
- + Measure the length of the module field **1** and mark the line.
- + Measure the width of the module field **2** and mark the line.
- + Place the start feet, connectors and end feet in the module field **3**.

Edge rows: Place the starting feet, connectors and end feet with end clamps.

Middle rows: Place the starter feet, connectors and end feet with centre clamps.

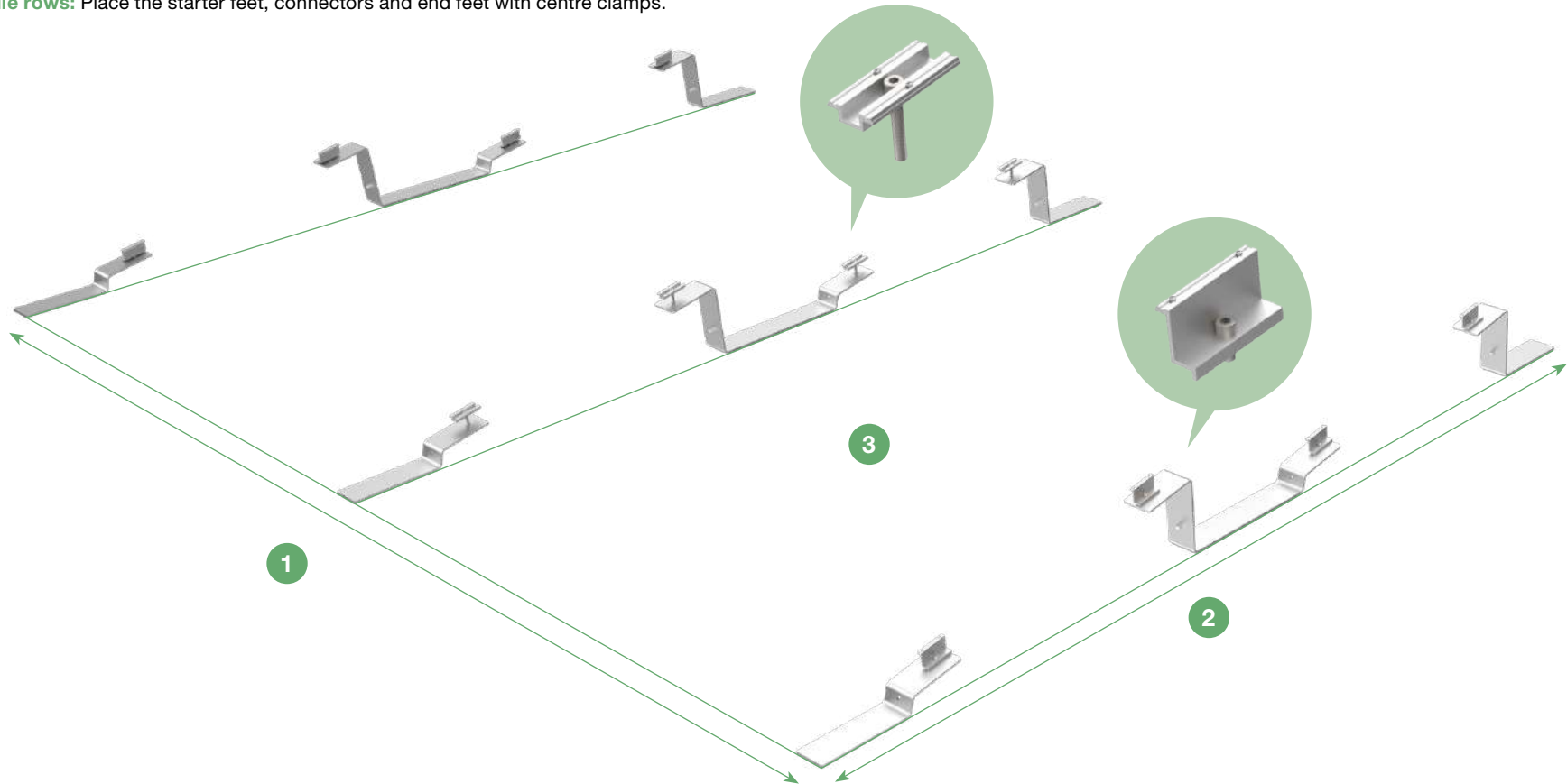

INSTALLATION

INSTALLING MODULES

Tip: Wire the modules already during installation.

The cables can be attached to the module using the cable tie clip.

The distance between the clamps is determined by the feet / connectors or the module size.

Installing the first row of modules

- + Position the feet / connectors so that the clamps are flush with the module.
- + Tighten the clamps carefully. Make sure that the feet / connectors are straight.
- + Weigh down the initial feet with ballast stones **1**.
- + Place the module on the feet or connectors **2**.

When mounting the modules, make sure that the feet / connectors at the module field edge are straight.

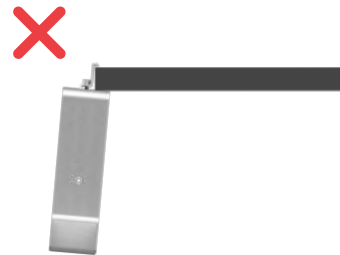
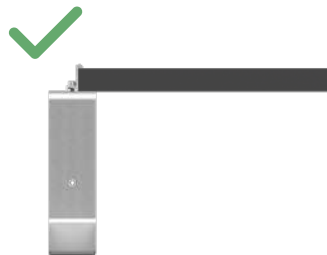
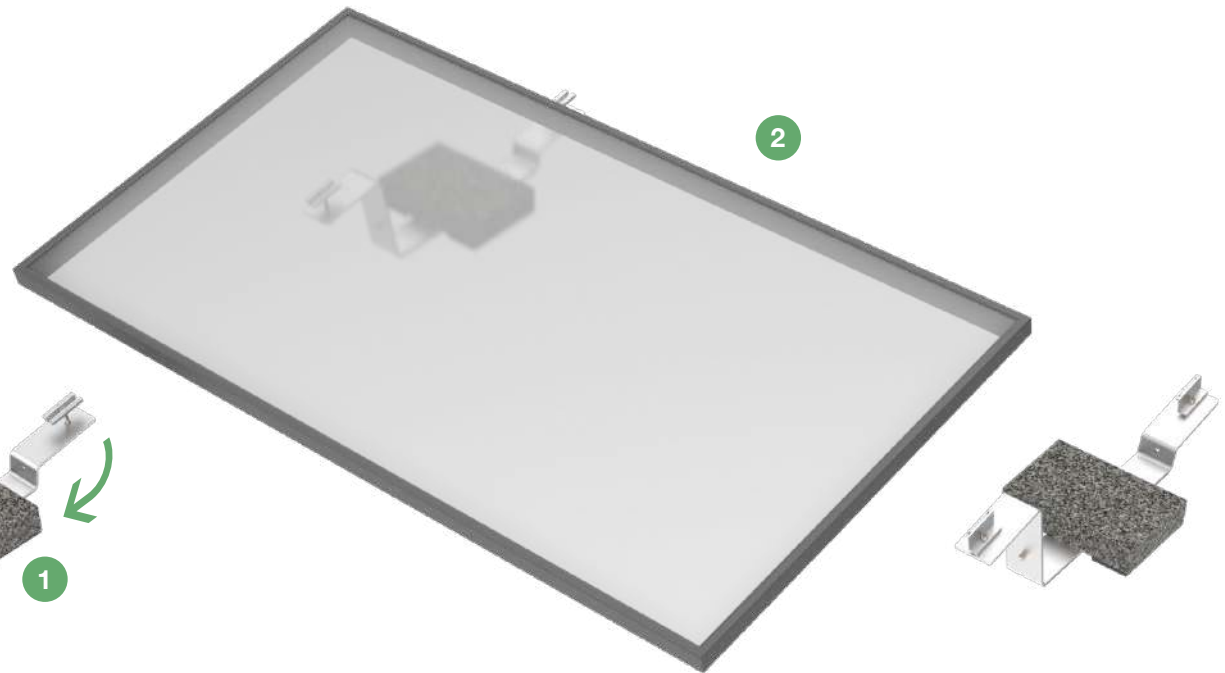

INSTALLATION – VARIANT EASYLIGHT S5 30°

INSTALLING MODULES

- + Align each module with the notches on the start leg.
- + Fit the module at the rear with a 150 mm overhang.
- + Tighten the screws on the end clamps to 15 Nm.
- + In the last row of modules, fit the modules to the notches on the end feet.

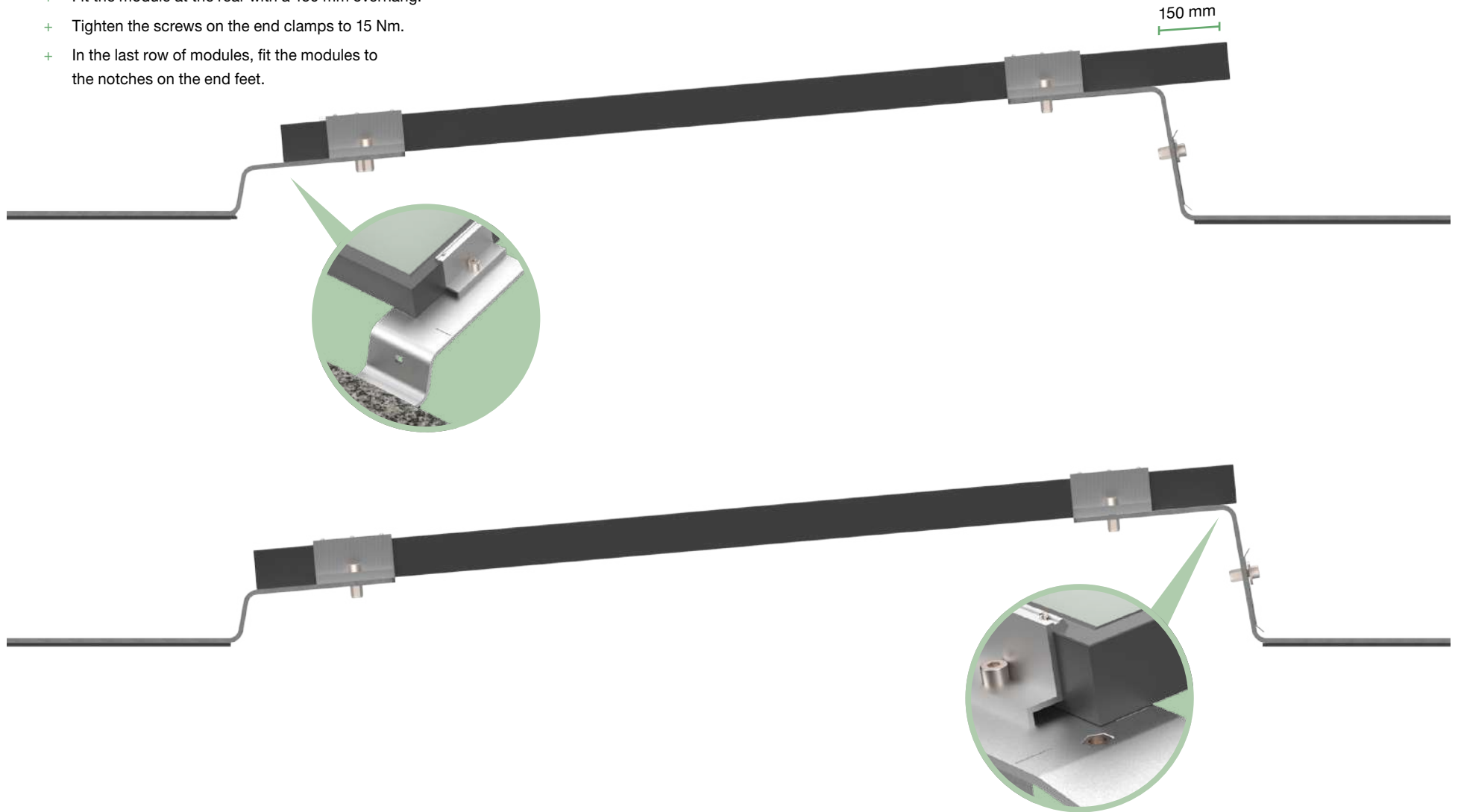

INSTALLATION – VARIANT EASYLIGHT S5 18°, S10 UND S15

INSTALLING MODULES

- + Align the module with the notches on the feet / connectors.
- + Tighten the screws on the end clamps to 15 Nm.

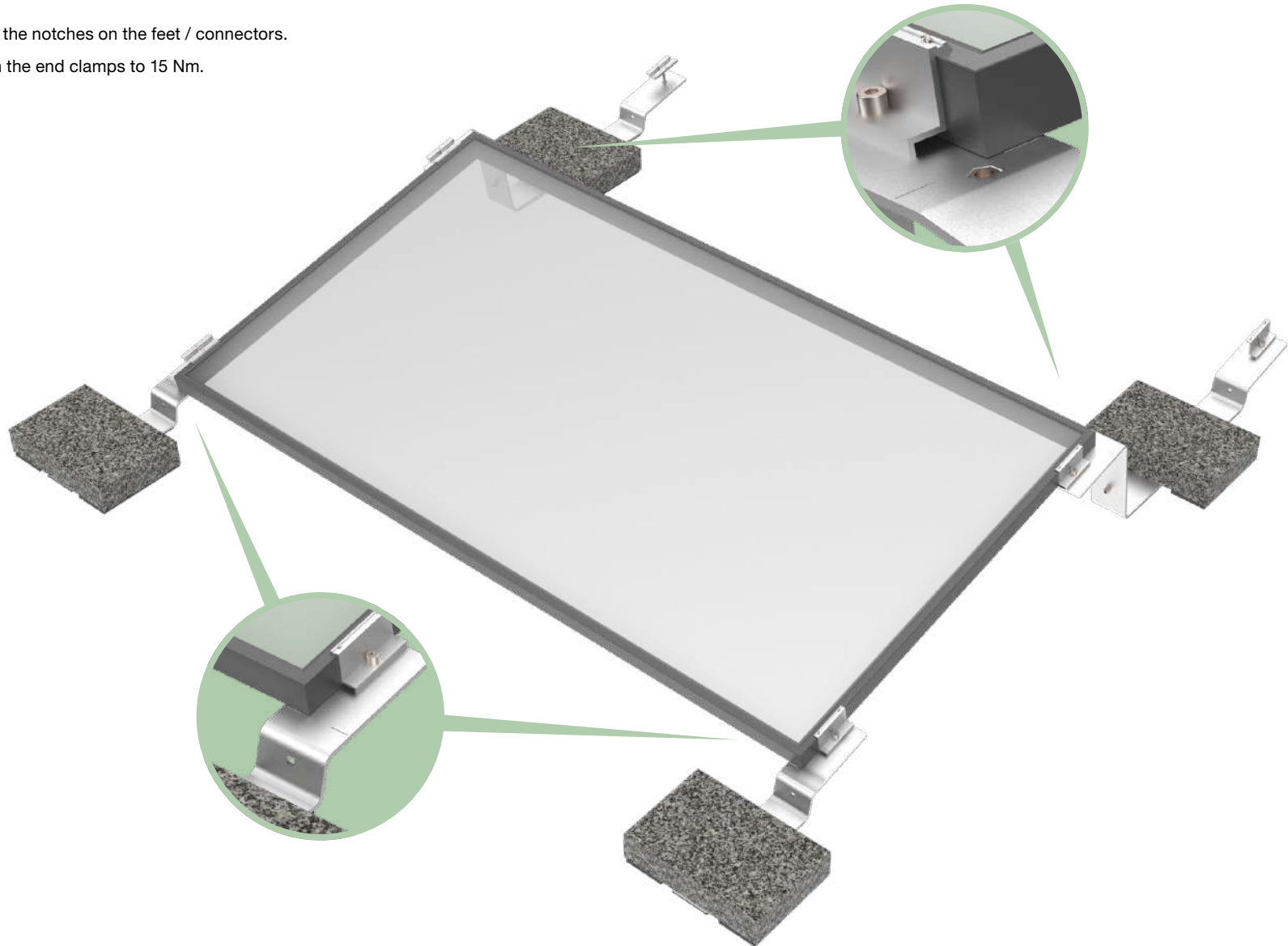

INSTALLATION

INSTALLING MODULES

- + Position the next module **1**.
- + Tighten the screws on the centre clamps **2** of the previous module with 15 Nm.

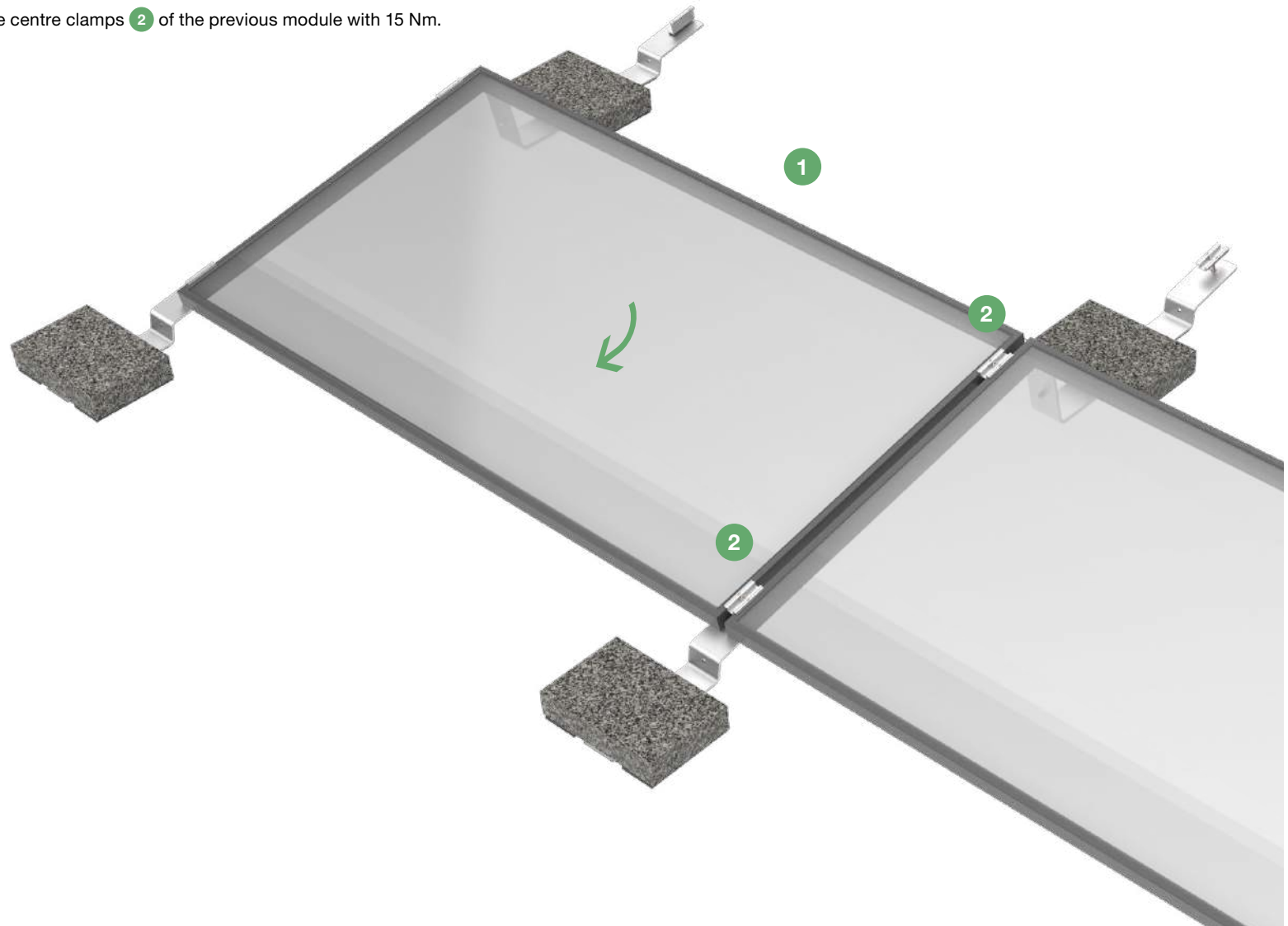

INSTALLATION

INSTALLING MODULES

- + Place clamps at the marked points and tighten the screws to 15 Nm.

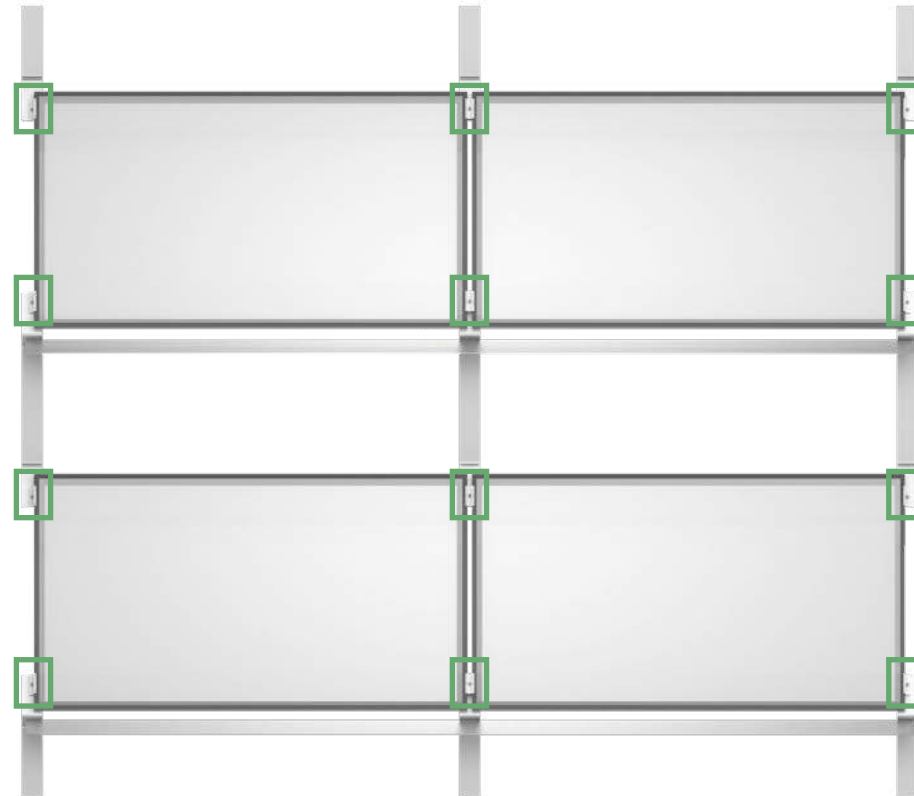

OPTIONAL: INSTALLING ALPINE SUPPORTS

INSTALLING MODULES

Above a certain snow load, additional support legs (Alpine supports) are mounted in the centre of the module. Whether Alpine supports are required can be seen from the planning documents.

Before installing the Alpine supports, ensure that the modules are suitable for increased snow loads and that the clamping is suitable for the intended clamping area.

- + Attach an end clamp to the front **1** and rear **2** alpine support attach an end clamp.

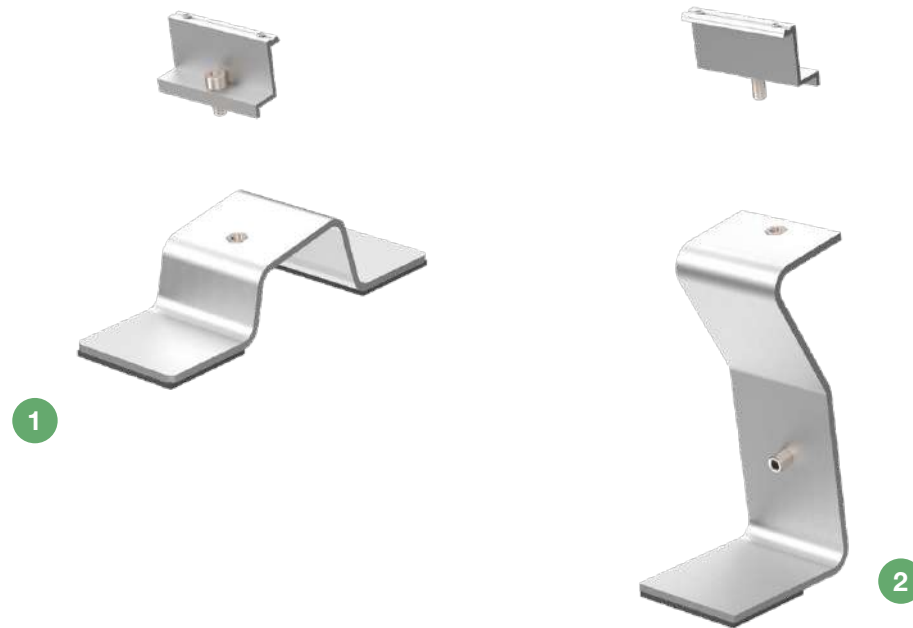

OPTIONAL: INSTALLING ALPINE SUPPORTS

INSTALLING MODULES

- | The alpine supports are mounted in parallel with the modules.
- + Place one front **1** and one rear **2** alpine support in the centre of each module.
- + Ensure that the end clamps are flush with the module.
- + Tighten the screws with 15 Nm.

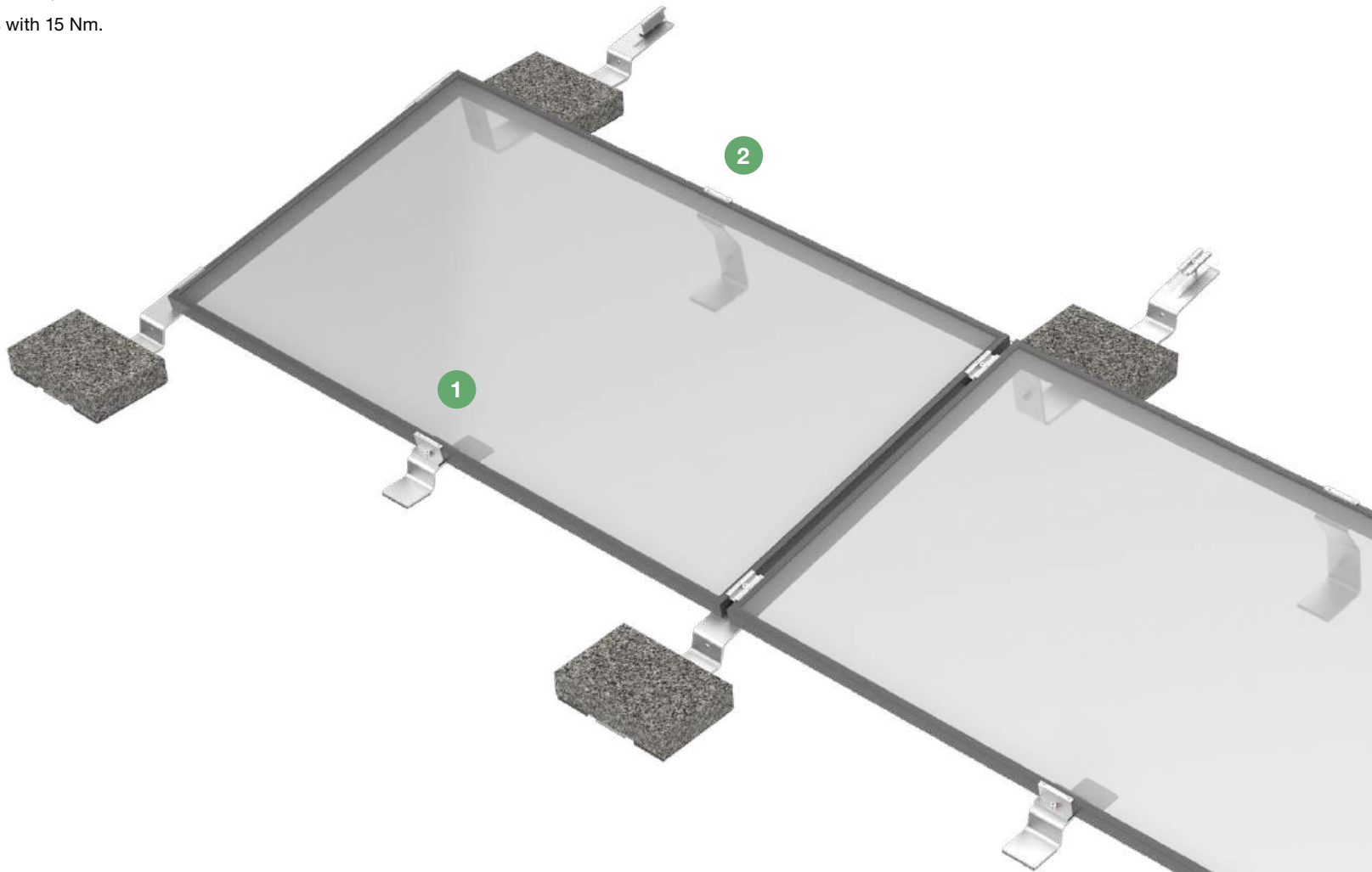

INSTALLING WIND DEFLECTION

Never leave the construction site until the wind deflectors have been fitted.
There is a risk of personal injury and damage to property!

Complete all cabling work before installing the wind deflectors.

VARIANT EASYLIGHT S5

With the easyLIGHT S5 flat roof, the long ballast trays can replace the wind deflectors. Wherever long ballast trays are fitted, do not fit wind deflectors.

- + Lay the wind deflectors **1** on the back of the connectors or overlap the end feet.
- + If Alpine supports are fitted: Screw the wind deflectors to the lower hole with the Alpine supports.
- + Screw the wind deflector plates to the slotted holes with the connectors or end feet **2**.
- + Tighten the screws to 15 Nm.

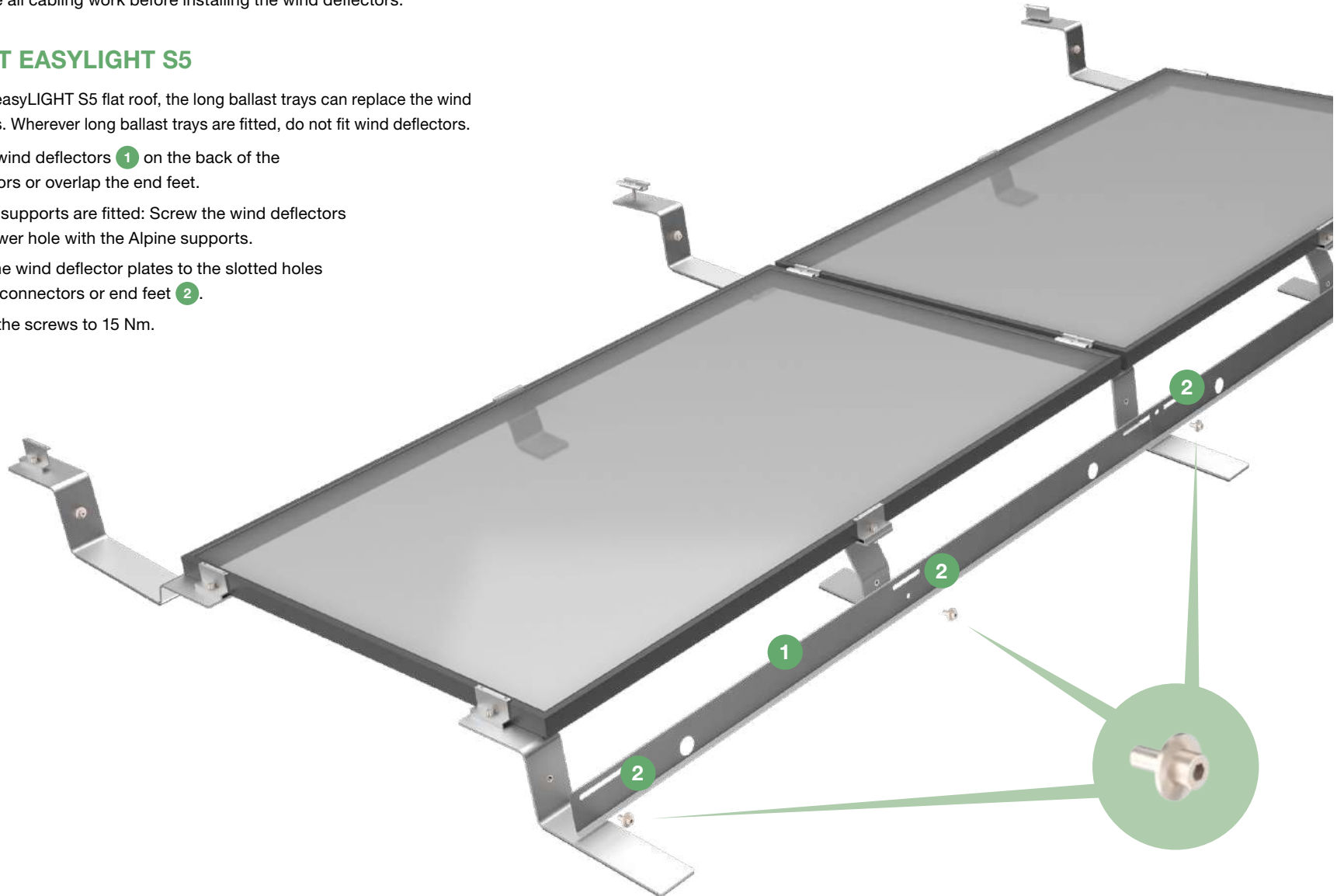

INSTALLING WIND DEFLECTION

VARIANT EASYLIGHT S10

In order to minimise the installation effort, the wind deflectors are fitted together with the ballast trays.

- + Lay the wind deflectors **1** on the back of the connectors or overlap the end feet.
- + If Alpine supports are fitted: Screw the wind deflectors to the lower hole with the Alpine supports.
- + Screw the wind deflector plates to the slotted holes with the screw on the connectors or end feet **2**.
- + Tighten the screws to 15 Nm.
- + Attach the clip **3** at the overlap point.

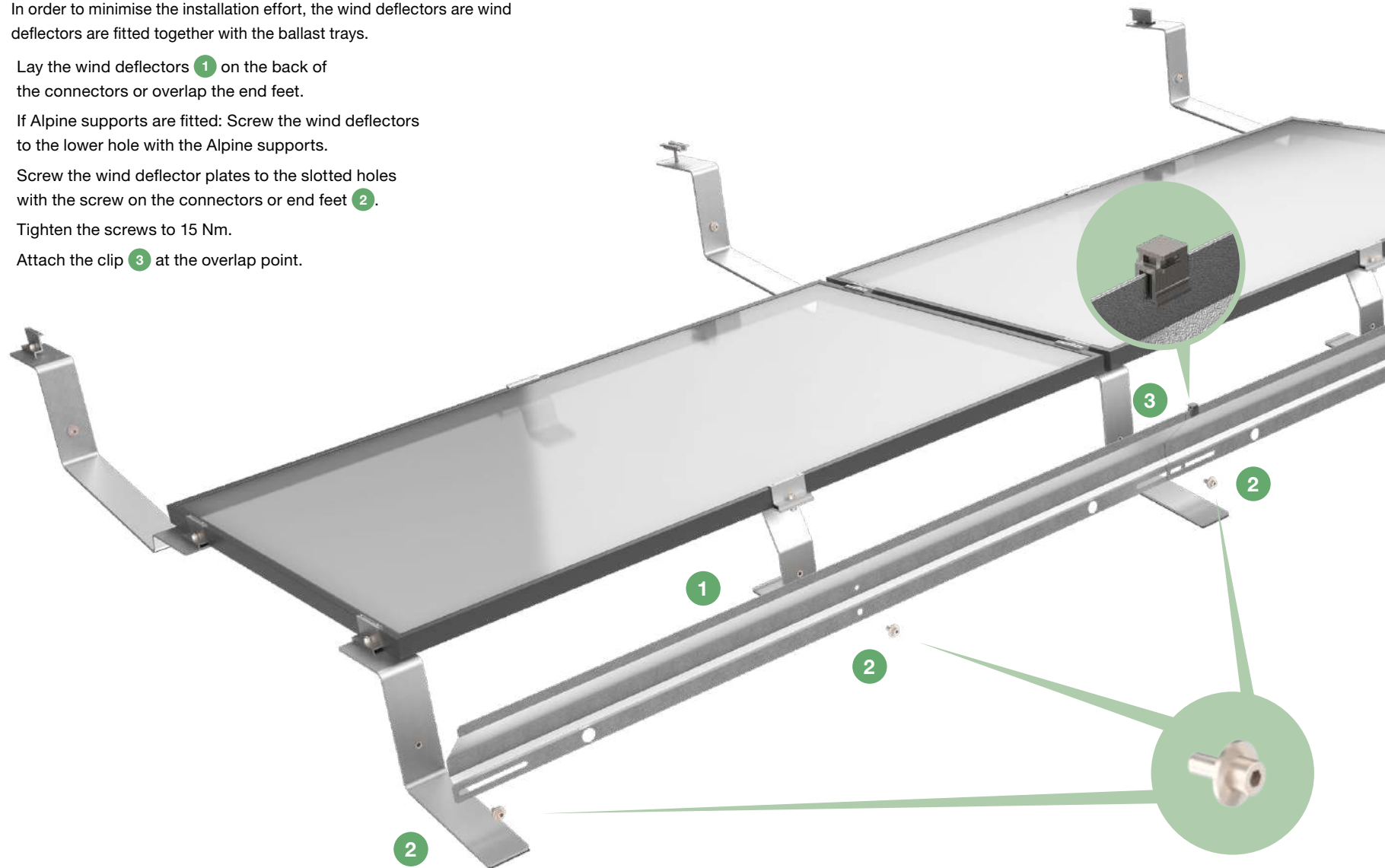

INSTALLING WIND DEFLECTION

VARIANT EASYLIGHT S15

The wind deflectors are fitted together with the ballast trays to minimise the installation work.

- + Lay the wind deflectors **1** on the back of the connectors or overlap the end feet.
- + If Alpine supports are fitted: Screw the wind deflectors to the Alpine supports with 2 screws each.
- + Screw the wind deflectors to the slotted holes with the connectors or end feet using 2 screws each. **2**
- + Tighten the screws to 15 Nm.
- + Attach the clip **3** at the overlap point.

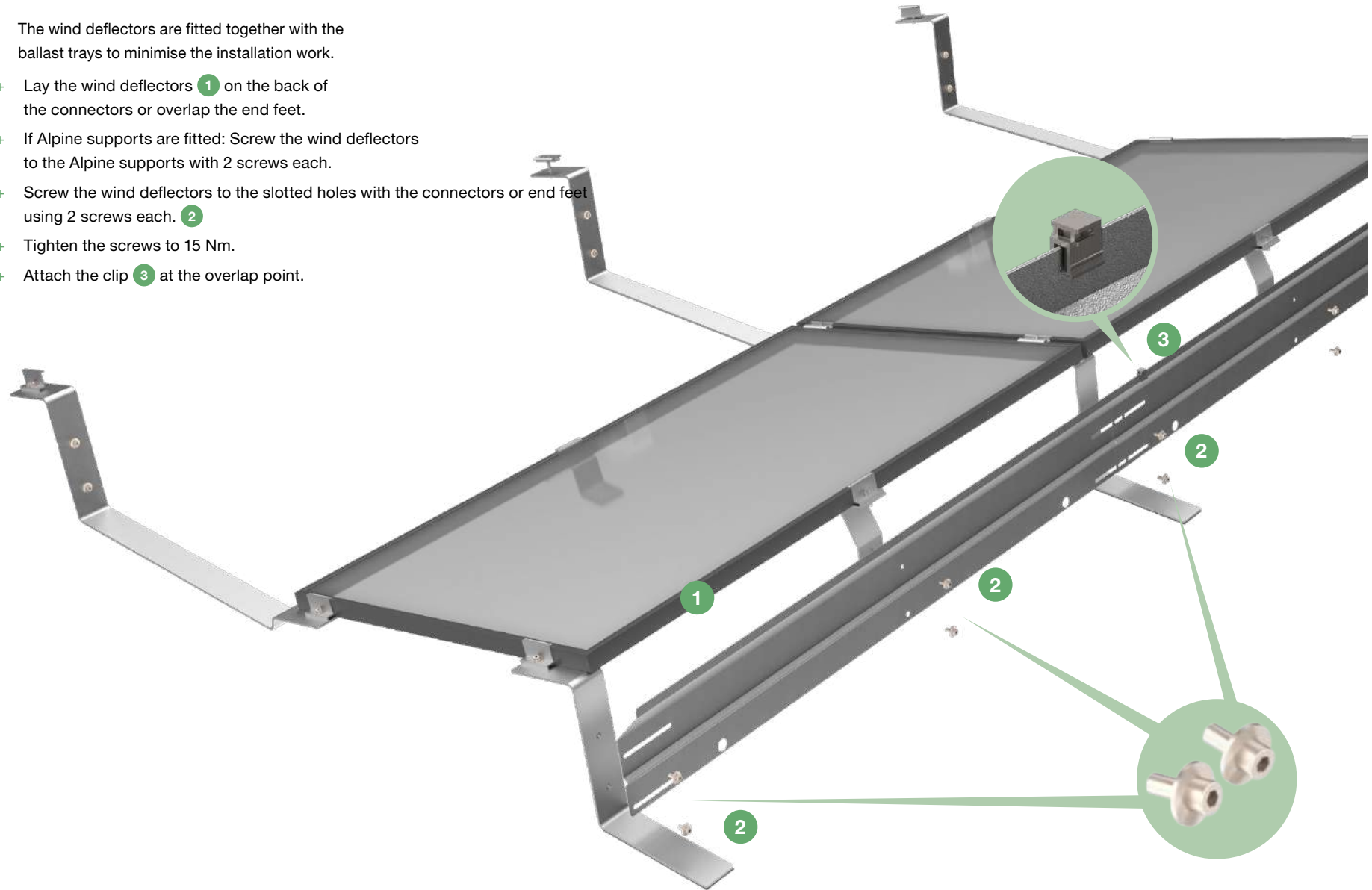

INSTALLING BALLASTAGE

| The system is ballasted differently depending on the circumstances.

BALLASTIERUNG BEI KIESDÄCHERN

Install the system on waterproofing or protective fleece

- + Install ballast troughs according to plan.
- + Use the existing gravel for ballasting according to the ALUMERO.PRO.TOOL report.
- + Spread the remaining gravel evenly over the roof.
- + Ensure that there is sufficient gravel on the entire roof.
Add gravel if necessary.

INSTALLING BALLASTAGE

VARIANT 1: BALLASTING DIRECTLY ON THE START OR END FEET

With this ballasting variant, the ballast blocks are placed directly onto the the starting feet, connectors or centre supports.

Refer to the ALUMERO.PRO.TOOL planning documents for the exact number and position of the ballast blocks.

Recommendation: Glue the building protection mats and ballast blocks with a weather-resistant building adhesive.

- + For height levelling, position building protection mats **1** to the right and left of the of the start or end foot.
- + Place the ballast stone **2** on top.

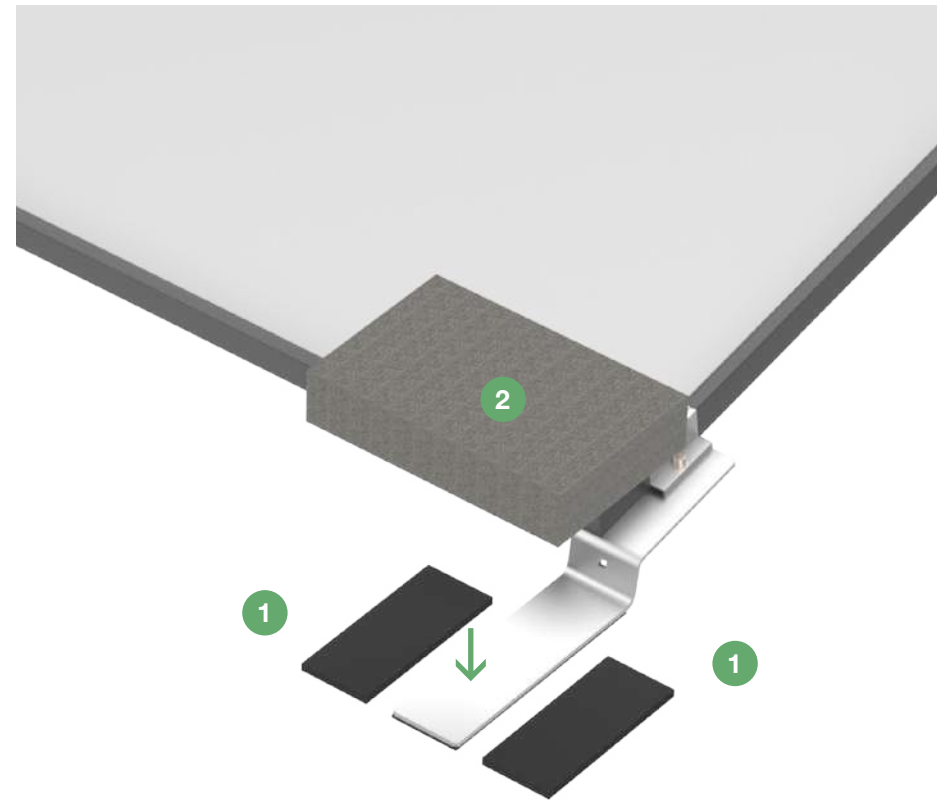

INSTALLING BALLASTAGE

VARIANT 2: SHORT BALLAST TRAY

The short ballast tray can be fitted in the following positions:

- 1 at the starting foot
- 2 on the connector
- 3 at the end foot

The exact number and position of the short ballast trays can be found in the ALUMERO.PRO.TOOL planning documents.

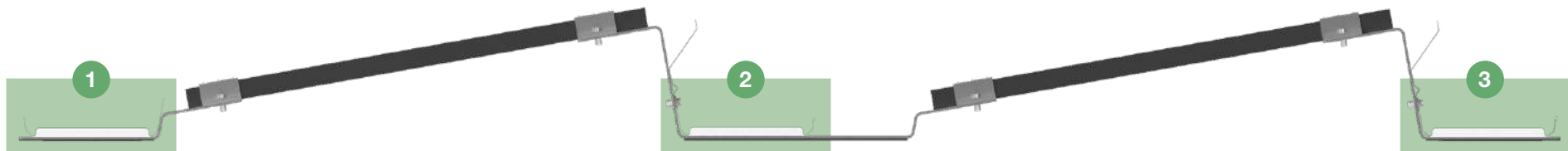

INSTALLING BALLASTAGE

VARIANT 2: SHORT BALLAST TRAY

Installing the short ballast tray

- + Position the building protection mats **1** on the right and left at the edge of the ballast tray.
- + Place the ballast tray **2** in the centre of the base or connector.
- + Tighten the ballast tray **2** on the initial foot with the hinge bolt, washer and Allen nut **3**.
- + Screw the ballast tray **2** to the wind deflector at the connector and end foot using the existing Allen screw **3**.
- + Tighten the screws to 15 Nm.

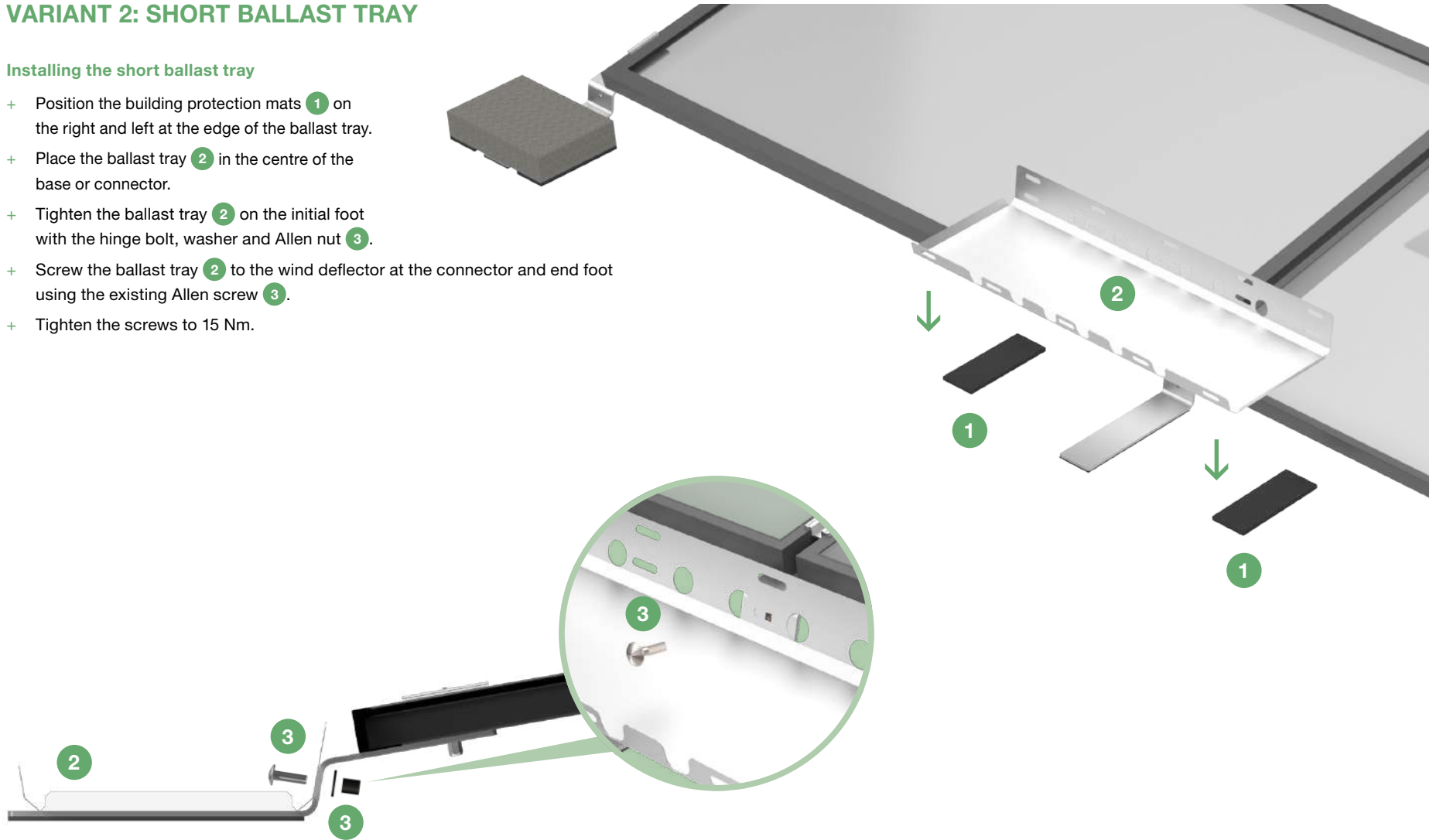

INSTALLING BALLASTAGE

VARIANT 2: LONG BALLAST TRAY

The long ballast tray can be attached in the following positions:

- 1 at the starting foot
- 2 on the connector
- 3 at the end foot

The exact number and position of the long ballast trays can be found in the ALUMERO.PRO.TOOL planning documents.

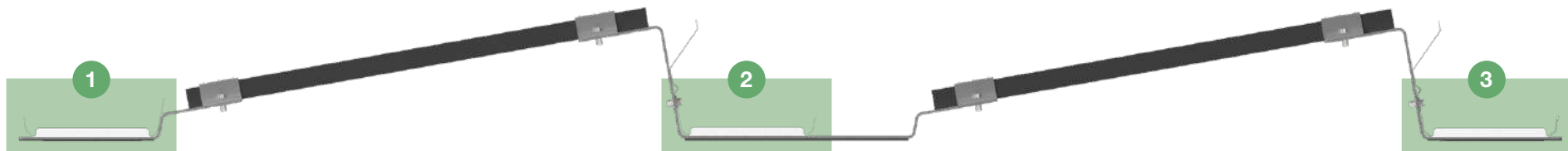

INSTALLING BALLASTAGE

VARIANT 3: LONG BALLAST TRAY

Placing building protection mats

Depending on the length of the ballast tray, a different number of building protection mats are required per ballast tray:

Length 1800 mm: 3 structural protection mats per ballast tray

Length 2050 mm: 4 structural protection mats per ballast tray

Length 2300 mm: 5 structural protection mats per ballast tray

When positioning the building protection mats, ensure that the drainage holes are not covered.

+ Distribute building protection mats evenly under the ballast trays.

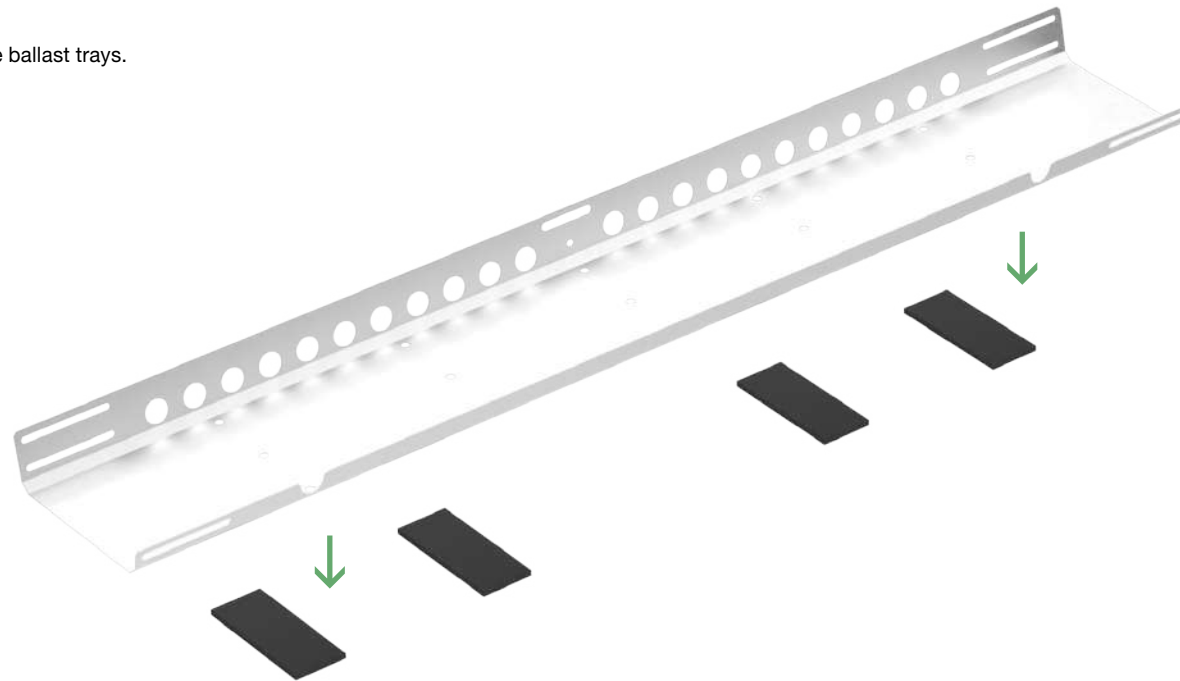

INSTALLING BALLASTAGE

VARIANT 3: LONG BALLAST TRAY EASYLIGHT S5

With the easyLIGHT S5 system, the long ballast trays can replace the wind deflectors. Wherever long ballast trays are fitted, no wind deflectors are fitted.

- + If several ballast trays follow one another:
Lay out the ballast trays so that they overlap at the connectors or end feet **1**.
- + Fasten the ballast tray to the supports with a hinge bolt or Allen screw **2**.
- + Tighten the screws to 15 Nm.

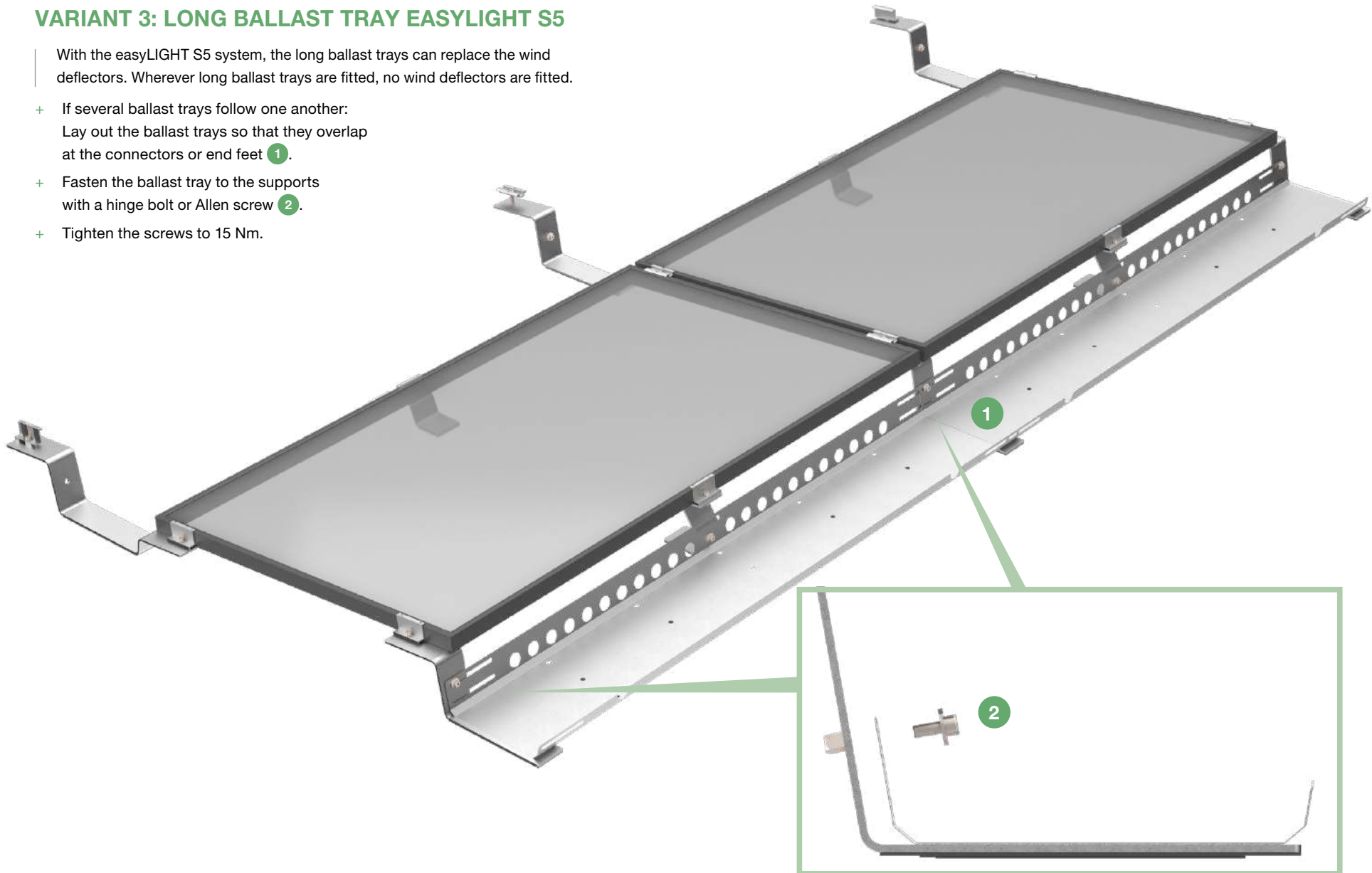

INSTALLING BALLASTAGE

VARIANTE 3: LONG BALLAST TRAY EASYLIGHT S10, S15

With the easyLIGHT S10 and S15 systems, the ballast tray is installed together with the wind deflectors.

- + If several ballast trays follow one another:
Lay out the ballast trays so that they overlap at the connectors or end feet **1**.
- + Screw the ballast tray to the supports using a hinge bolt or Allen screw **2**.
- + Tighten the screws to 15 Nm.

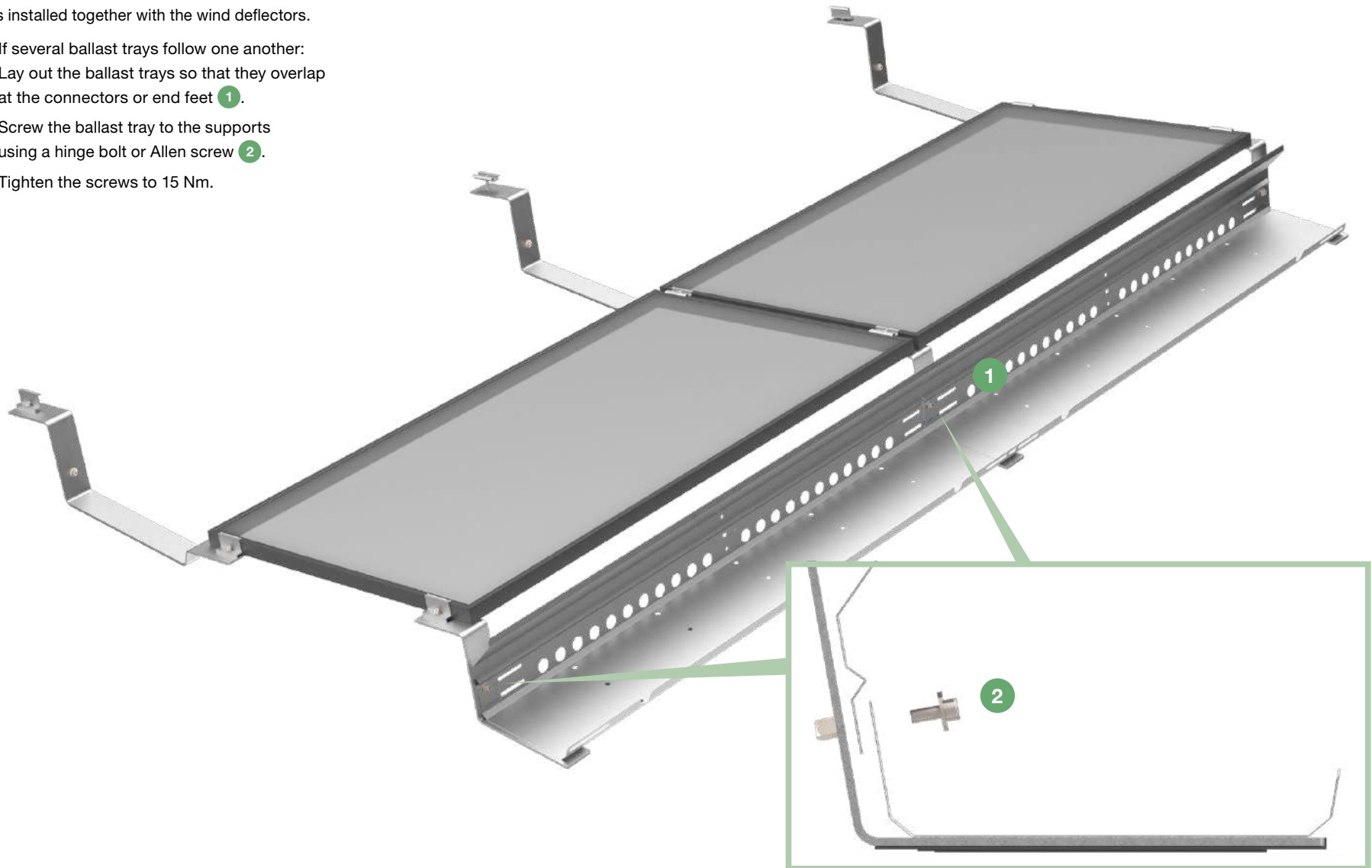

OPTIONAL: INSTALLATION OF ROOF ANCHORS

ROOF ANCHOR DIMENSIONING

The roof anchors must be provided by the customer and are not included in the scope of delivery. To install the roof anchor connection, the roof anchors must be fitted on site with a threaded rod with a maximum size of M10.

Refer to the ALUMERO.PRO.TOOL planning documents for the number and positions of the roof anchors.

ALUMERO.PRO.TOOL only marks the component on which the roof anchor is mounted.

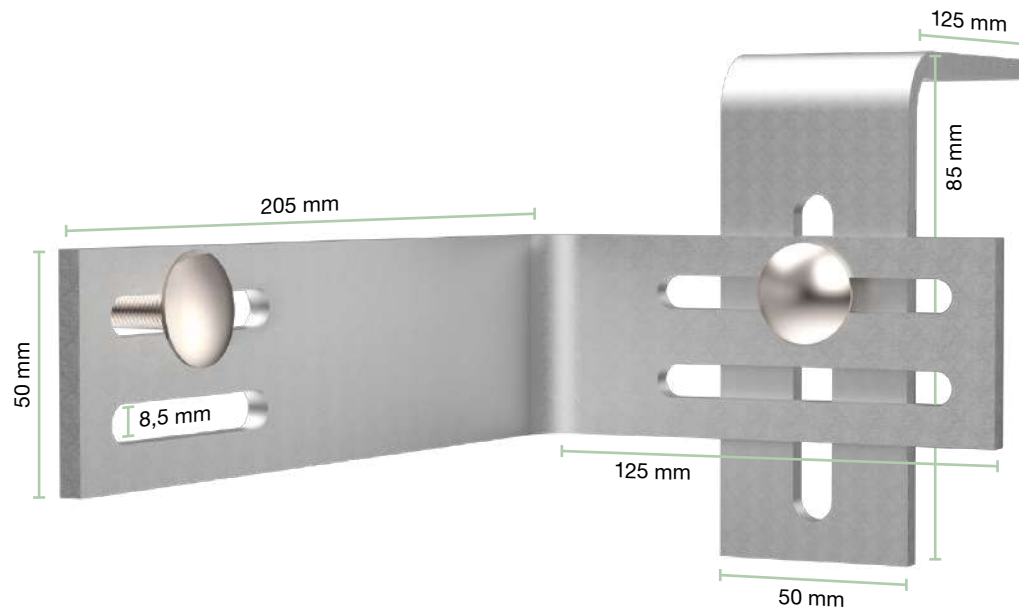

OPTIONAL: INSTALLATION OF ROOF ANCHORS

CONNECT THE SYSTEM WITH A MOUNTING BRACKET

- + Position the angle connector **1** and the bracket **2** flush with each other.
- + Connect the angle connection **1** and bracket **2** to the slotted holes using the Allen screws provided **3**.
- + Connect both angle connectors **1** with the hinge bolt, washer and Allen nut **4**.
- + Screw the angle connector **1** to the roof anchor prepared on site.
- + Tighten the screws **3**, **4** to 15 Nm each.

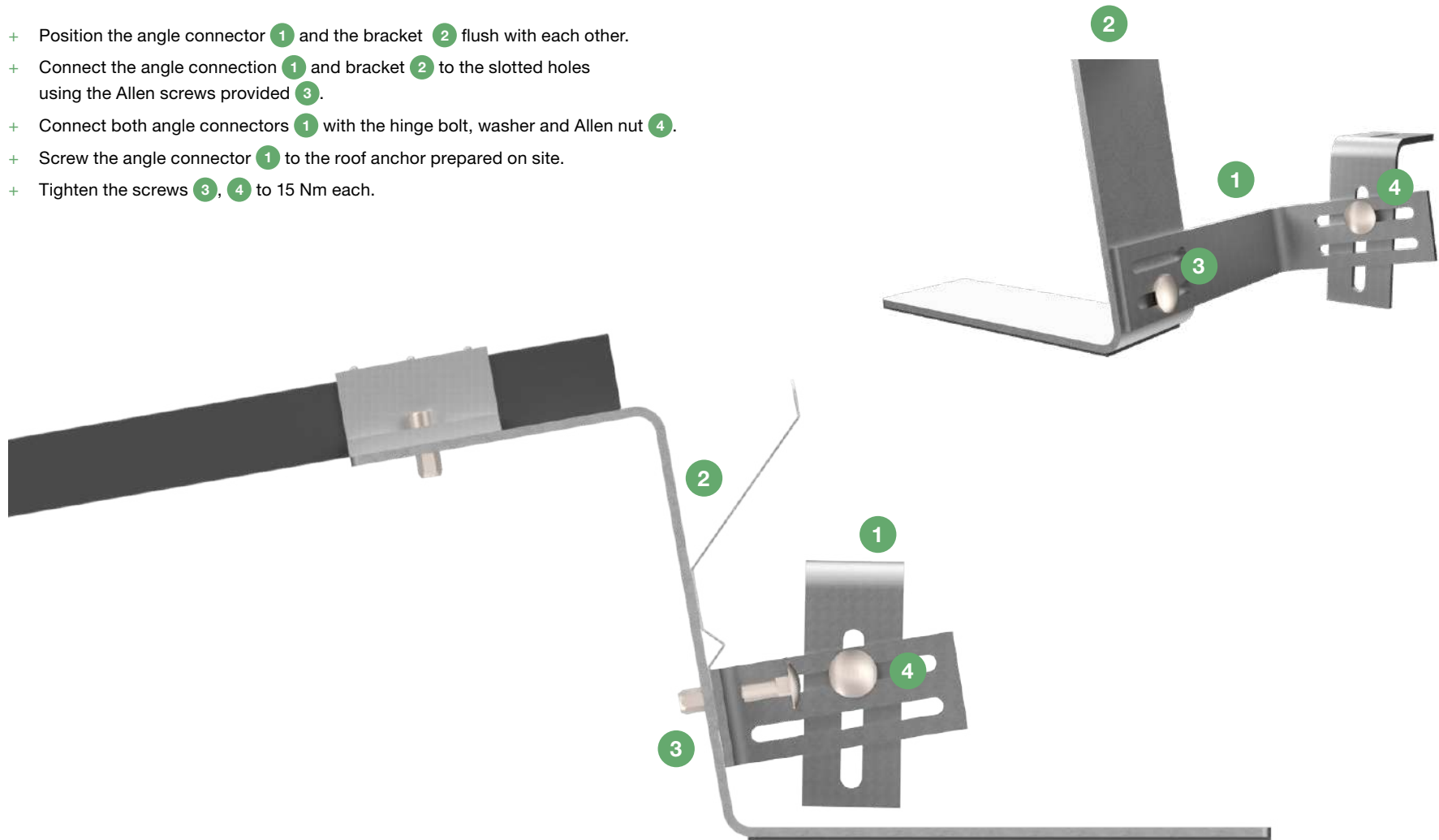

OPTIONAL: GROUNDING / POTENTIAL EQUALISATION

The earthing / potential equalisation is attached to the edge of a module field on a base with a screw (max. M8). The components are not included in the scope of delivery.

- + Connect the earthing wire (provided by the customer) **1** firmly to the cable lug **2**.
- + Attach the washer **3** and cable lug **2** with the screw **4** in the order shown.

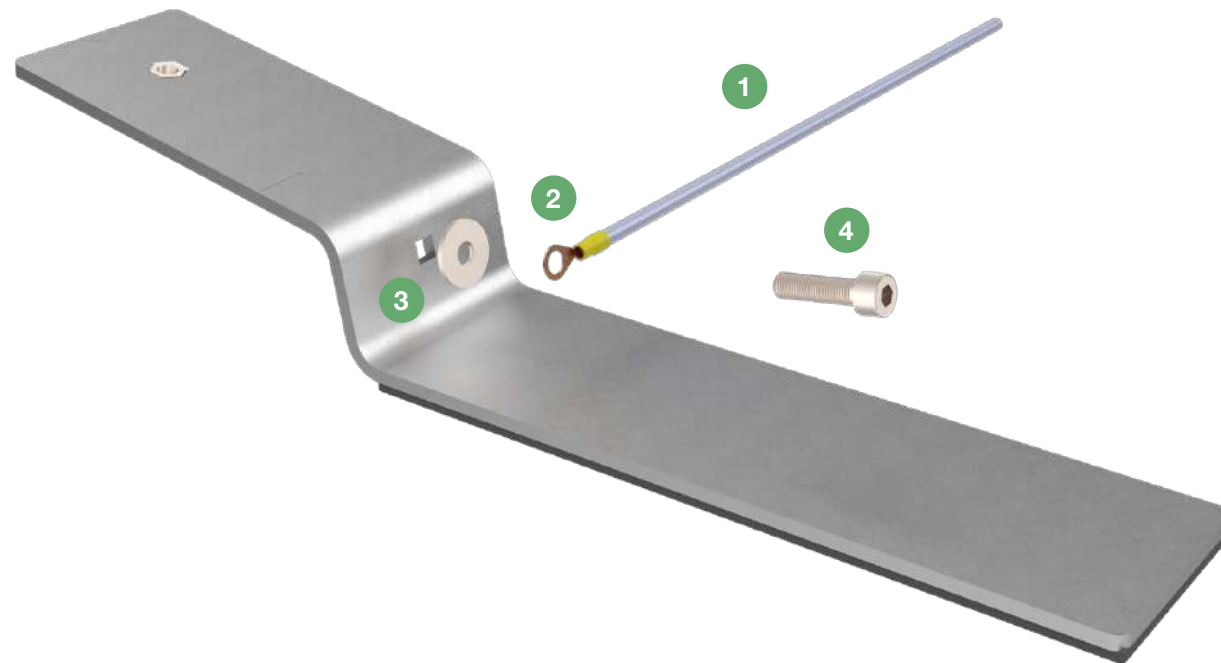

PLEASE NOTE THE FOLLOWING ADDITIONAL DOCUMENTS!

The following documents are required in addition to the installation instructions and for correct installation of the system:

- + Project report from ALUMERO.PRO.TOOL
- + Planning documents and drawings
- + The generally applicable document "Installation instructions" at <https://www.alumerogroup.eu/service> under "General" -> "Other"

Please also inform yourself about the safety regulations of the other system components.

**CONGRATULATIONS,
WELL DONE!**



**SUSTAINABLE
SOLAR
SOLUTIONS**